

D-BOX

G3

G3 HAPTIC SYSTEM

USER GUIDE

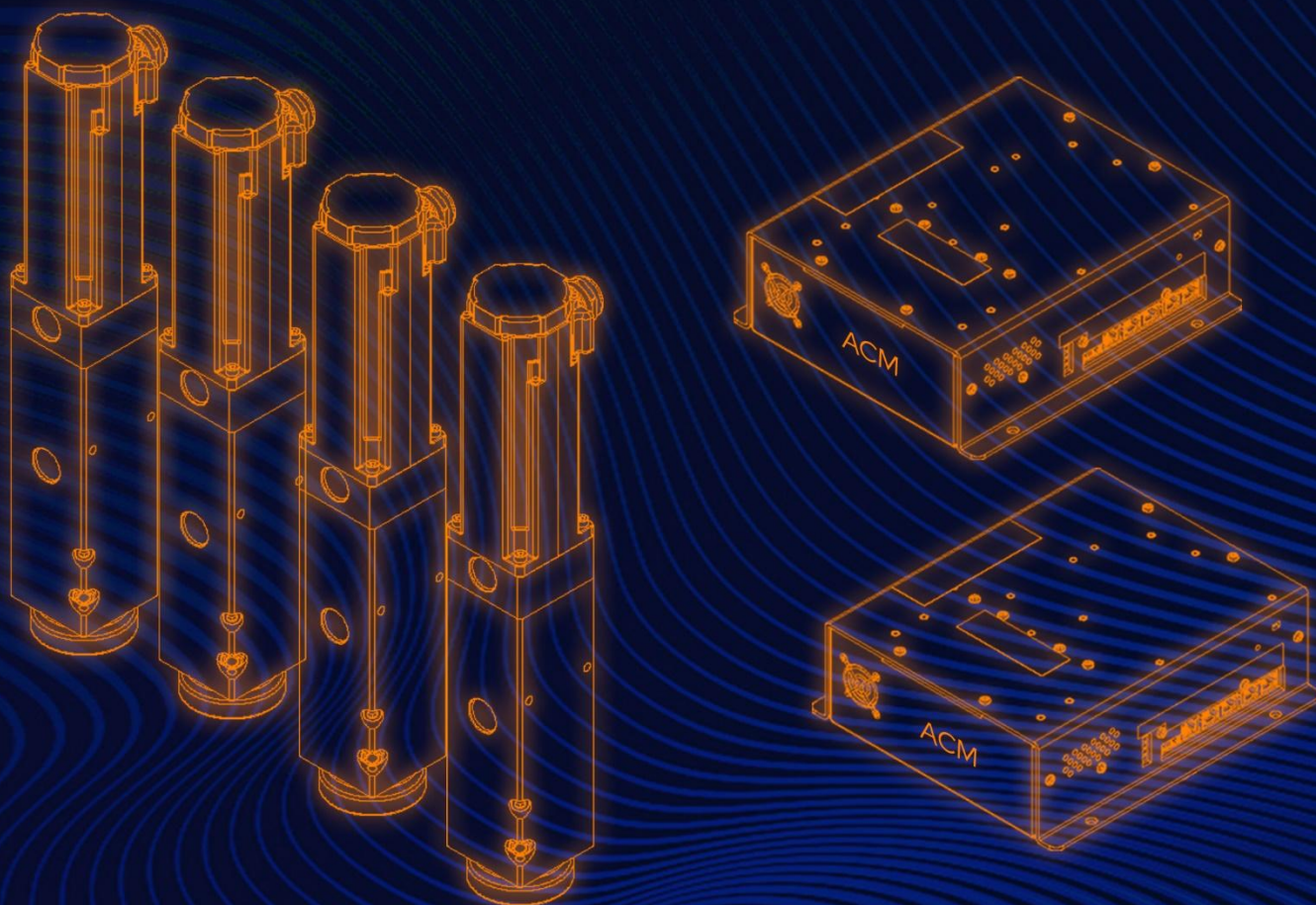

TABLE OF CONTENTS

IMPORTANT SAFETY INSTRUCTIONS..... 4

1. INTRODUCTION..... 6

 1.1 G3 Haptic System Specifications (with ACM G3 FLEX)..... 7

 1.2 Package Contents 8

2. INTEGRATION INFORMATION FOR COMMERCIAL USE..... 9

3. SOFTWARE INSTALLATION..... 9

 3.1 Minimum System Requirements (PC)..... 9

4. D-BOX System Configurator 10

5. D-BOX HaptiSync Center 13

 5.1 Haptic Output Tab 15

 5.2 D-BOX Adaptive Gaming Configurator 17

 5.3 D-BOX System Monitor Recorder 18

 5.4 D-BOX Stimuli Presenter 19

6. COMMUNICATION UNIT 20

 6.1 Communication Unit Power Up..... 21

7. ACTUATOR CONTROL MODULE (ACM)..... 22

 7.1 ACM Families and Compatibility 22

 7.2 Voltage Selection..... 22

 7.3 ACM Door Installation (6-inch travel haptic systems only) 22

 7.4 ACM Connections (with KCU-1X Communication Unit) 23

8. ACTUATORS 25

 8.1 Maximum Axial Load..... 25

 8.2 Weight Distribution 25

 8.3 Actuator Acceleration 26

 8.4 Distance Between Actuators..... 26

 8.5 Actuator Alignment..... 26

 8.6 Actuator Levelling..... 27

 8.7 Level Surface..... 27

 8.8 Usage of 6-inch Actuators for Lateral Motion 27

9. ACTUATOR ENDING INSTALLATION (OPTIONAL)..... 28

 9.1 Non-captive Ending Installation (Optional) 28

 9.2 Captive Ending Installation (Optional) 28

10. BRACKET INSTALLATION..... 37

 10.1 U-Bracket Installation 37

 10.2 L-Bracket Installation..... 38

 10.3 H-Bracket Installation 38

11. HAPTIC SYSTEM OPERATION..... 40

12.	TROUBLESHOOTING	40
12.1	Initial Troubleshooting Steps	40
12.2	Reinitiate/Reset Haptic System	40
12.3	Update Software and Firmware	42
12.4	Troubleshooting with Communication Unit LED Statuses	42
12.5	Troubleshooting Hardware Issues (D-BOX HaptiSync Center).....	44
12.6	Possible Faults and Corrective Actions.....	46
12.7	Troubleshooting Software Issues (D-BOX HaptiSync Center)	50
	APPENDIX A - INFORMATION FOR COMMERCIAL USE	52
	APPENDIX B - G3 HAPTIC SYSTEMS USING OLDER ACM VERSIONS (ACM G3 or ACM G2 with a KCU-1P).....	54
	APPENDIX C - MIXING G5 AND G3 HAPTIC SYSTEMS (ACM G3 FLEX ONLY connected to a KCU-1X)	59

IMPORTANT SAFETY INSTRUCTIONS

- Read, keep, and follow these instructions.
- Heed all warnings:



This D-BOX haptic system may be harmful to women who are pregnant, persons with heart conditions, the elderly, or those with other pre-existing medical conditions. All such persons should consult their physicians before using this D-BOX haptic system.



Use of this D-BOX haptic system is not recommended for children under the age of ten years old without adult supervision. Owners and/or users of this D-BOX haptic system should consult and comply with the user guide enclosed.



Use of this D-BOX haptic system is a risk to hands and feet. Do not put hands or feet underneath the seat or near the haptic system. This may lead to serious injury.



Unplug this device during electrical storms or when unused for long periods of time.



Use of hot liquids in the vicinity of this D-BOX haptic system should always be avoided to prevent spillage which could cause serious injuries to the user.



Do not install near any heat sources such as radiators, heat registers, stoves or any other appliances (including amplifiers).



Do not use this device near water.



Refer all servicing to qualified personnel. Servicing is required when the device has been damaged in any way. For example: if liquid has been spilled or objects have fallen onto it, if it has been exposed to rain or moisture, if it does not operate normally or, it has been dropped.



- Only clean the device with a dry cloth.
- Do not block any ventilation openings. Install in accordance with the manufacturer's instructions.
- Protect all the cables (USB, network, power, etc.) from being walked on or pinched, particularly at the ends.
- Use only attachments/accessories specified by the manufacturer.

Owners and/or users of this D-BOX haptic system are responsible for the dissemination of this information to all such persons named herein. Each owner and/or user of this D-BOX haptic system agrees to evaluate and bear all risks associated with the use of this D-BOX haptic system for themselves and for any subsequent users of this D-BOX haptic system and any subsequent users of this D-BOX haptic system shall be deemed to be using this D-BOX haptic system under the direct supervision of such owner/user and such owner/user will be deemed to have communicated this advisory to all persons described herein.

D-BOX Technologies Inc. is in no way responsible for any damages of any kind arising from the use of this D-BOX haptic system and the owners and/or users of this D-BOX haptic system hereby agree not to hold D-BOX Technologies Inc. responsible for any and all damages of any kind arising from the use of this D-BOX haptic system including, but not limited to direct or indirect, punitive, incidental, special or consequential damages arising out of or in any way connected with the use of this D-BOX haptic system.

Thank you for purchasing a D-BOX haptic system, the most immersive experience for the simulation and game markets. We strongly advise that you read these guidelines before assembling and using your haptic system.

This user guide details the information for the G3 haptic systems, which include the newest ACM technology (ACM G3 FLEX). Most of the information included also applies to G3 systems using a previous ACM G3. Refer to section 11 for specific connection information using ACM G3.

Support information

Please make sure to provide the **serial numbers** of your haptic system (ACM & actuators) when contacting your reseller support team (or the D-BOX Technical Support team if you are an integrator and your system was bought directly from D-BOX).

NOTE: For 3 and 4-actuator systems, there may be more than one sequence of serial numbers.

The serial numbers (in yellow) are located on the haptic components and available (in its shortened form) under Diagnostics in the Haptic Output tab of D-BOX HaptiSync Center.

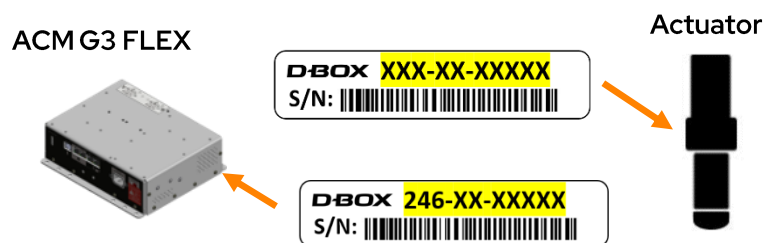

If you have questions:

- Contact your official D-BOX reseller.
- Contact D-BOX Technical Support if you purchased directly from D-BOX.
- You can also visit the Help Center section of our [website](#) to access our Knowledge Base or chat with D-Buddy, our chatbot.

If remote assistance is required, you must have [TeamViewer](#) installed on your PC.

D-BOX Technical Support

2172 rue de la Province, Longueuil, Québec, Canada, J4G 1R7

BY EMAIL: support@d-box.com

BY PHONE: 1-888-442-3269 ext. 931 (toll-free CAN/US)
1-450-442-3003 ext. 931 (other regions)



1. INTRODUCTION

D-BOX haptic systems are evolutive and scalable. Integrated into a seat, platform, or simulator, they are designed to simulate a range of textures, vibrations and scalable axes of movement. With our G3 haptic system, benefit from a robust and compact actuator form factor while retaining the same core architecture and software integration process that lifted D-BOX ahead of its competitors. This updated version of our renowned G3 haptic system now comes with our ACM G3 FLEX that features a 120/230V switch for flexible power configurations.

The following components are part of a D-BOX G3 haptic system.

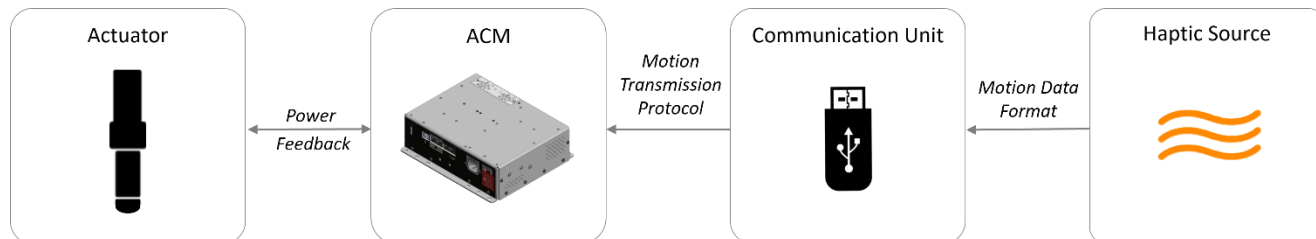

- Haptic system:** A complete architecture of hardware and software providing haptic feedback.
- Actuator:** An assembly of motor and mechanics providing motion, texture and vibrations.
- ACM (Actuator Control Module):** The controller provides power and control to the actuators. It also controls the power sent to the motor and adjusts the precise rotation according to feedback from an encoder within the actuator.
- Communication Unit:** Electronic component used for transmitting the haptic code, converting one signal format to another.
- Haptic Source:** Various applications generating haptic codes for the D-BOX haptic system.

1.1 G3 Haptic System Specifications (with ACM G3 FLEX)

	1.5 inches		3 inches		6 inches
Performance Under Maximum Load	250i / 250 HD	400i / 400 HD	250i-3	400i-3	500 HD- 6
Maximum Lifting Capacity	250 lbs / 113 kg	400 lbs / 182 kg	250 lbs / 114 kg	400 lbs / 182 kg	500 lbs / 226 kg
Maximum Stroke	1.5 inch / 38.1 mm		3 inch / 76.2 mm		6 inch / 152.4 mm
Maximum Velocity	100 mm/s		100 mm/s		100 mm/s
Maximum Acceleration	+/- 1 g-force		+/- 1 g-force		+/- 1 g-force
Frequency Range	0-100 Hz		0-100 Hz		0-100 Hz
Operating Temperature Range	0-40 °C		0-40 °C		0-40 °C
Operating Hygrometry	10 to 85% (free from condensing)		10 to 85% (free from condensing)		10 to 85% (free from condensing)
Horizontal Load	Translation on limited friction surfaces can be done on weights up to 3 times vertical lifting capacity.				

			1.5 inches		3 inches		6 inches	
Power Requirements			Average Power*	Peak Current**	Average Power*	Peak Current**	Average Power*	Peak Current**
120 V 50/60 HZ	250 lbs	1-2 actuators	213 W	3.75 A	240 W	3.75 A	-	-
		3-4 actuators	426 W	7.5 A	480 W	7.5 A	-	-
	400 lbs	1-2 actuators	290 W	3.75 A	320 W	3.75 A	-	-
		3-4 actuators	580 W	7.5 A	640 W	7.5 A	-	-
	500 lbs	1-2 actuators	-	-	-	-	400 W	3.75 A
		3-4 actuators	-	-	-	-	800 W	7.5 A
230 V 50/60 HZ	250 lbs	1-2 actuators	213 W	3.75 A	266 W	3.75 A	-	-
		3-4 actuators	426 W	7.5 A	533 W	7.5 A	-	-
	400 lbs	1-2 actuators	310 W	3.75 A	373 W	3.75 A	-	-
		3-4 actuators	620 W	7.5 A	746 W	7.5 A	-	-
	500 lbs	1-2 actuators	-	-	-	-	400 W	3.75 A
		3-4 actuators	-	-	-	-	800 W	7.5 A

* To be used for electric consumption

** to be used for breaker specifications

1.2 Package Contents

Package contents may vary depending which G3 haptic system you acquired.

For haptic systems with 1.5-inch travel

Part Number	Description	250lb / 1.5 inch (i and HD)				400lb / 1.5-inch (i and HD)			
		1250	2250	3250	4250	1400	2400	3400	4400
850-NXX	Actuator	1	2	3	4	1	2	3	4
850-N203	ACM G3 FLEX	1	1	2	2	1	1	2	2
000-100-0579-Z00	Hex bolts, M6 X1.0 X16mm	10	10	20	20	10	10	20	20
102-0051	Lock Washer, 1/4	10	10	20	20	10	10	20	20
000-090-0056-Z00	Shielded ethernet cable - 1 foot	1	1	2	2	1	1	2	2
000-090-0136-Z00	Shielded ethernet cable - 13 feet	1	1	2	2	1	1	2	2
000-090-0010-Z00	Power cable (US)	1	1	2	2	1	1	2	2
000-090-0017-Z00	Power cable (Euro)	1	1	2	2	1	1	2	2

For haptic systems with 3-inch travel

Part Number	Description	250lb / 3-inch (i and HD)				400lb / 3-inch (i and HD)			
		1250-3	2250-3	3250-3	4250-3	1400-3	2400-3	3400-3	4400-3
850-NXX	Actuator	1	2	3	4	1	2	3	4
850-N203	ACM G3 FLEX	1	1	2	2	1	1	2	2
100-0551	Hex bolts, 1/4-20 X 3/4	10	10	20	20	10	10	20	20
102-0051	Lock Washer, 1/4	10	10	20	20	10	10	20	20
000-090-0056-Z00	Ethernet cable - 1 foot	1	1	2	2	1	1	2	2
000-090-0136-Z00	Ethernet cable - 13 feet	1	1	2	2	1	1	2	2
000-090-0010-Z00	Power cable (US)	1	1	2	2	1	1	2	2
000-090-0017-Z00	Power cable (Euro)	1	1	2	2	1	1	2	2

For haptic systems with 6-inch travel

Part Number	Description	500lb / 6-inch (HD)			
		1500-6	2500-6	3500-6	4500-6
850-NXX	Actuator	1	2	3	4
850-N203	ACM G3 FLEX	1	1	2	2
100-0422	Screw, Quadrex, #6-32 X 3/8	6	6	12	12
209-130-0023-B01	ACM access door	1	1	2	2
209-130-0055-A01	ACM actuator door	1	0	1	0
000-090-0056-Z00	Ethernet cable - 1 foot	1	1	2	2
000-090-0136-Z00	Ethernet cable - 13 feet	1	1	2	2
000-090-0010-Z00	Power cable (US)	1	1	2	2
000-090-0017-Z00	Power cable (Euro)	1	1	2	2

- Installation hardware included:
 - Communication Unit (e.g. KCU-1X, KCU-1P)
 - Actuator endings (captive/non-captive (optional))
 - USB cable
 - Bolts with lock washers for actuator installation
- Power options included:
 - US power cable (120V)
 - Euro power cable (230V)
- Assembly components included (Required for 6-inch travel haptic systems (field assembly required))
 - ACM access door
 - ACM actuator door (for system with odd actuator number only)
 - Mounting screws

2. INTEGRATION INFORMATION FOR COMMERCIAL USE

If your system is used in an integration for commercial use, refer to [Appendix A - Information for Commercial Use](#) for more details on:

- Software integration/API
- Mechanical integration
- Haptic code integration

3. SOFTWARE INSTALLATION

There are two (2) D-BOX software packages to install: **D-BOX HaptiSync Center** and **D-BOX System Configurator**. Both are available on our [website](#).

You will also need to set up your D-BOX Connect account: [D-BOX Connect](#) is used for haptic code distribution and authorization service. The account is required to install and update haptic codes for D-BOX Coded Gaming and to access haptic codes for D-BOX Coded Video.

3.1 Minimum System Requirements (PC)

Here are the minimum requirements to run the D-BOX software on your computer:

- Microsoft Windows 10 x64 (1809 or later) or Windows 11
- 512 MB of free RAM for D-BOX Coded Gaming and an additional 1 GB if using D-BOX Coded Video mode
- 850 MB free space on drive for D-BOX Coded Gaming and an additional 23 GB for the D-BOX Coded Video haptic library
- USB port 2.0 Full Speed (or faster)

4.D-BOX System Configurator

D-BOX System Configurator is a free software tool for updating and configuring your haptic system.

IMPORTANT: As D-BOX upgrades the ACM firmware on a regular basis, we recommend that you update your equipment to the latest firmware version, upon reception, with System Configurator.

D-BOX System Configurator is compatible with Microsoft Windows 7, 8, 10 and 11 – 64 bit.

STEP 1: Download [D-BOX System Configurator](#).

STEP 2: Run the installer.

NOTE: The D-BOX System Configurator User Guide is included in your D-BOX folder (e.g. C:\Program Files\D-BOX).

STEP 3: Update your firmware:

- a) Ensure your haptic system is powered on and open D-BOX System Configurator (in the D-BOX folder).
- b) From the Firmware Update tab, click **Refresh Firmware Status**.
- c) If the system reads “Outdated (Update firmware)”, click **Update Firmware** and follow the instructions.



STEP 4: Update the configuration.

Each ACM comes with a default configuration based upon the haptic system architecture. Here is the list of the factory configurations. The letters representing the actuator position refer to the next table.

HAPTIC SYSTEM ARCHITECTURE	FACTORY CONFIGURATION	ACTUATOR POSITION (See figure below)	DESCRIPTION
1 Actuator	1 YAW	Y	One Main ACM with one horizontal actuator ensuring the YAW movement of the simulator.
2 Actuators	2 BACK	BL - BR	One Main ACM with two actuators at the back of the pivot point on the simulator.
3 Actuators	1 FRONT/2 BACK	FC - BL - BR	One Main ACM with two actuators at the back of the simulator. One Secondary ACM with one actuator at the front of the simulator.
4 Actuators	2 BACK/2 FRONT	BL - BR - FL - FR	One Main ACM with two actuators at the front end of the simulator. One Secondary ACM with two actuators at the back end of the simulator.

The letters represent the position of the actuators.

LEGEND	POSITION	PICTOGRAM REFERENCE
FL	Front-Left	
FC	Front-Center	
FR	Front-Right	
BL	Back-Left	
BC	Back-Center	
BR	Back-Right	
SU	Surge	
SW	Sway	
Y	Yaw	

You may have configuration requirements that differ from the factory configuration. If this is the case, you need to change it using D-BOX System Configurator to modify the configuration BEFORE you install your haptic system. System Configurator attributes a specific ACM port to each actuator position.

NOTE: *It is recommended to modify the dots on the sticker of your ACM to reflect the new configuration.*

The Configuration Update tab of System Configurator allows you to configure your haptic system (actuator positions and axes (Degrees of Freedom - DOF)):

- Select the Configuration Update tab. Click **Refresh Information**. Make sure the Actuator Count matches your system. If not, ensure that all power cables and RJ45 are firmly connected.
- Enter the configuration number matching your system or select the axes you want for your system.
- Once the configuration is selected, click **Apply Configuration** and confirm to start the configuration update process, then follow the instructions.

D-BOX System Configurator

Firmware Update
Configuration Update
ACM Rearrangement (G3 only)

Hardware Selection

Communication Device: D-BOX KCU (00003623) Platform: 1

Actual DOF Configuration

Configuration: 1025 Axes: Roll Yaw
Pitch Surge
Heave Sway

DOF Configuration Filter

Interface Count: 1 Actuator Count: 2 Configuration: Axes: Roll Yaw
Pitch Surge
Heave Sway

Configuration	Description
1020	RP - 2 Actuators - Front (as Back) 1 Intf (M-FR0-FL1)
1022	RP - 2 Actuators - Right (No Mix) 1 Intf (M-BR0-FR1)
1025	RP - 2 Actuators - Back (No Mix) 1 Intf (M-BL0-BR1)
1026	RP - 2 Actuators - Front (No Mix) 1 Intf (M-FR0-FL1)
10004	RP - 2 Actuators - Front 1 Intf (M-FR0-FL1)
10006	RP - 2 Actuators - Back 1 Intf (M-BL0-BR1)
10008	PH - 2 Actuators - Front/Back 1 Intf (M-FC0-BC1)
10010	YSw - 2 Actuators - 1 Intf (M-Y0-Sw1)
10012	YSu - 2 Actuators - 1 Intf (M-Y0-Su1)
10014	SwSu - 2 Actuators - 1 Intf (M-Sw0-Su1)

Compatible Configuration Selection

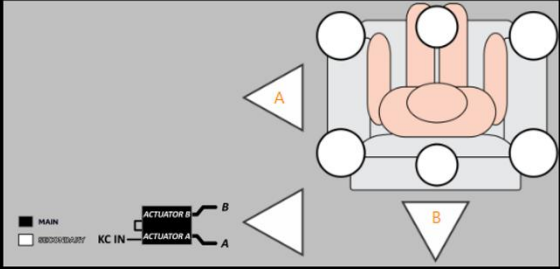

Actuator	Assignment	Position
A	Sway	Middle Center
B	Surge	Middle Center

Apply Configuration
Refresh Information

Execution Details

5. D-BOX HaptiSync Center

D-BOX HaptiSync Center is an application for managing all experiences enabled on your D-BOX haptic system. This software package includes the system’s driver in addition to the following software and utilities:

- D-BOX HaptiSync Center
- D-BOX Adaptive Gaming Configurator
- D-BOX System Monitor Recorder
- D-BOX Stimuli Presenter

You can download it from our [website](#). After downloading, simply install the software and follow the instructions.

IMPORTANT: HaptiSync Center must be activated on your PC. From the Software tab, go to the HaptiSync Activation verification button. The button displays a red exclamation icon and “Activation Required” if HaptiSync has not been activated. Click **Link** and follow the instructions (see [this article](#) for more details).

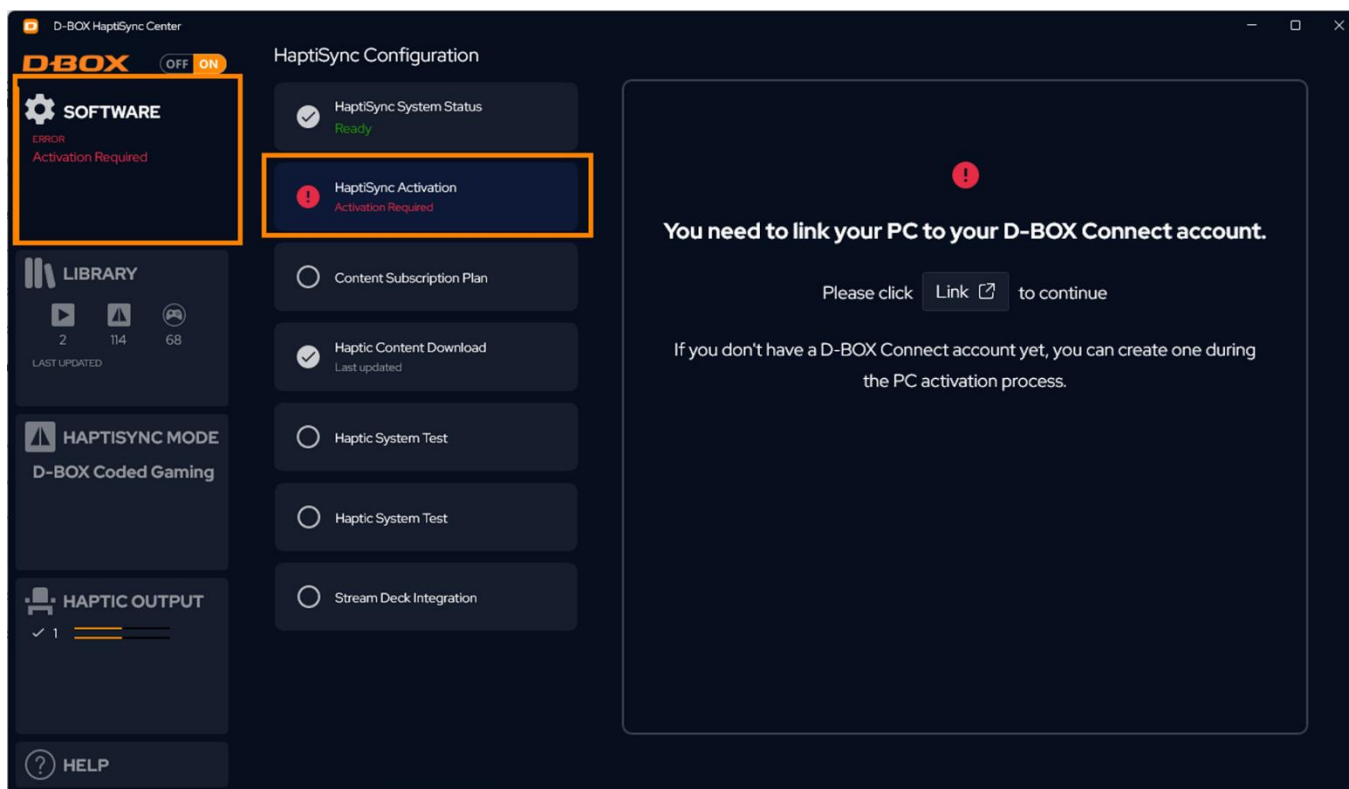

Using HaptiSync Center, you can choose your haptic experience in the HaptiSync Mode tab.

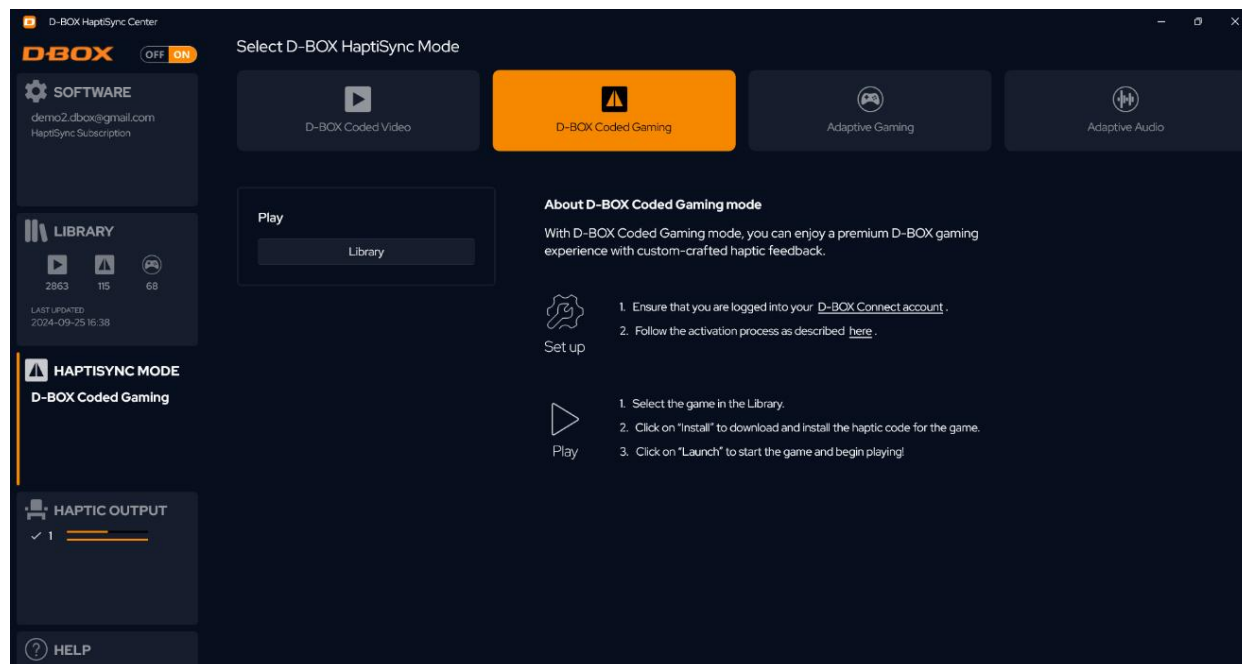

D-BOX Coded Gaming	Premium haptic experiences for D-BOX-coded apps, simulators and games. Use Adaptive Gaming mode for titles not listed. For detailed instructions, visit: https://support.d-box.com/en/knowledge/hsc-dbox-coded-gaming .
D-BOX Coded Video	Premium haptic experiences for D-BOX-coded movies and TV shows, using audio synchronization. For detailed instructions, visit: https://support.d-box.com/en/knowledge/hsc-dbox-coded-video .
Adaptive Gaming	Haptic experiences using real-time events, triggered by game controller or keyboard. For detailed instructions, visit: https://support.d-box.com/en/knowledge/hsc-adaptive-gaming .
Adaptive Audio	Automated haptic experiences for any movie, music, TV show or game using audio processing. For detailed instructions, visit: https://support.d-box.com/en/knowledge/hsc-adaptive-audio .

5.1 Haptic Output Tab

The Haptic Output tab in D-BOX HaptiSync Center provides essential tools for monitoring and managing your haptic system. It includes three sub-tabs: Settings, Status, and Diagnostics—each offering specific functions to ensure optimal performance and assist with troubleshooting.

5.1.1 Settings Tab

Contextual tooltips provide high-level information for these settings. Please refer to our [Knowledge Base](#) for more details. The following settings apply to all games on your computer.

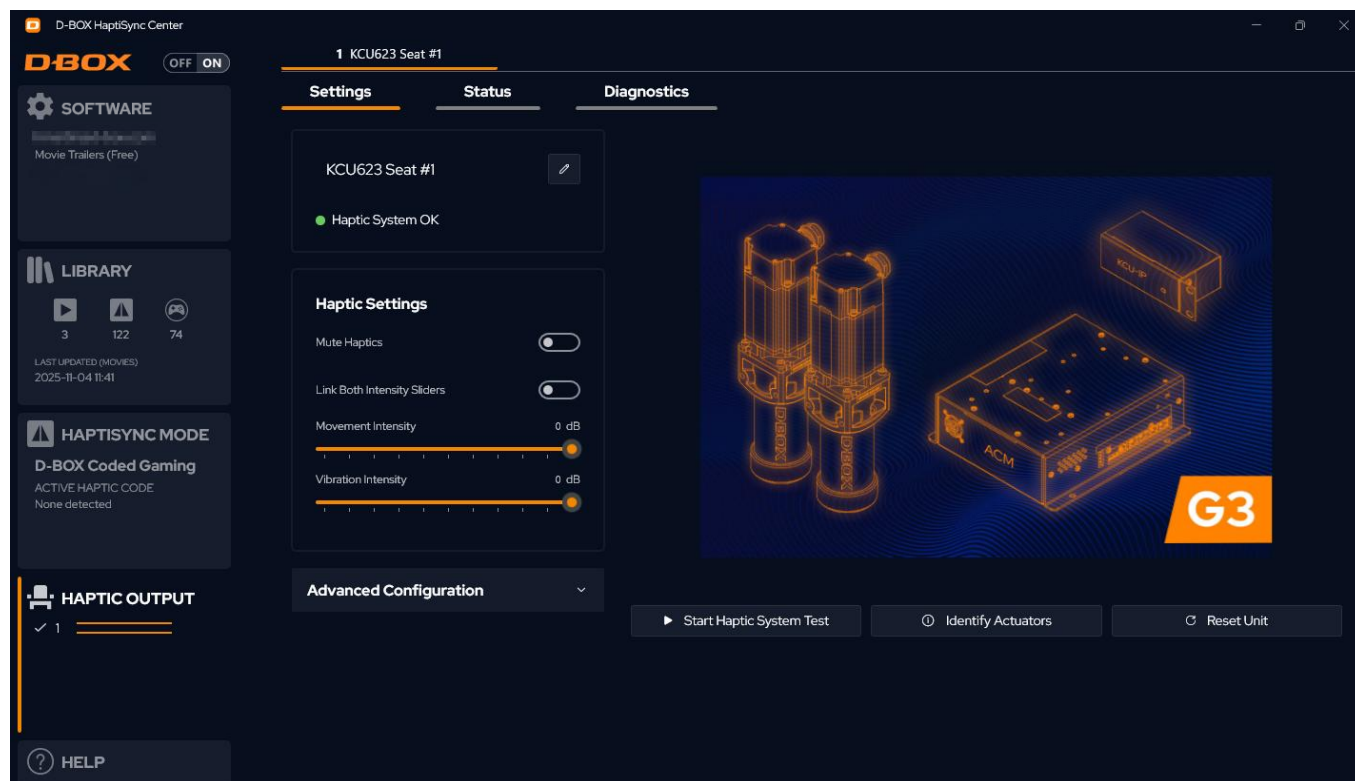

5.1.2 Status Tab

The Status tab displays the status of each component in your haptic system. All indicators should be green. Actuators in a Transition state are displayed as orange. Actuators in an Alarm state are displayed as red.

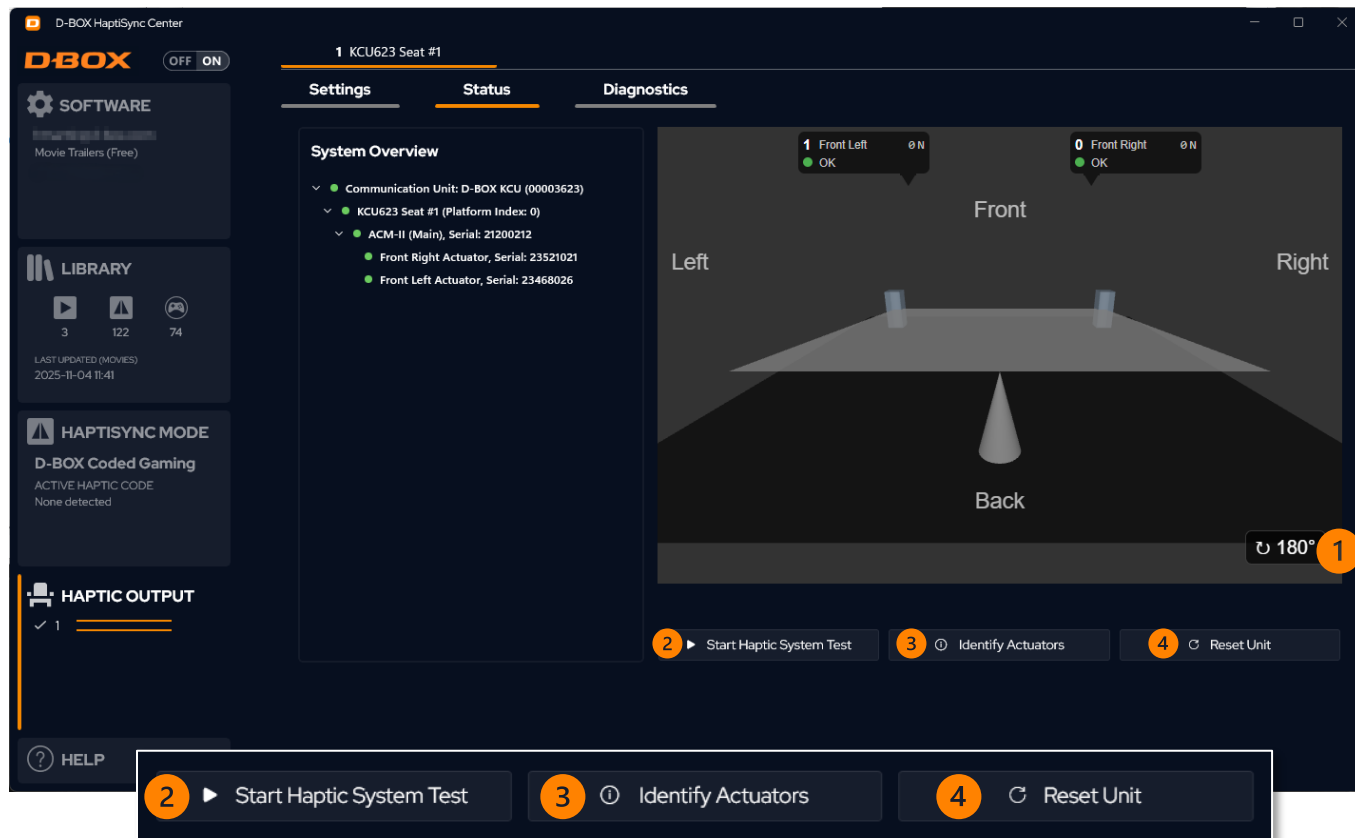

- 1 Use the **Rotate 180°** button to change the orientation of the 3D platform view.
- 2 Use the **Start Haptic System Test** button to test the hardware–software communication of the system by generating movement and vibration in a preset pattern.
- 3 Use the **Identify Actuators** button for interactive testing that validates that all actuators are located as expected on the platform.
- 4 Use the **Reset Unit** button to reset the D-BOX haptic system. Reset all your actuators to neutral (The platform will perform a homing sequence).

5.1.3 Diagnostics Tab

The Diagnostics tab displays real-time health status of the haptic system. If a component fails, related information appears in red.

The screenshot shows the 'Diagnostics' tab in the D-BOX HaptiSync Center. The main window displays a table of system parameters for '1 KCU623 Seat #1'. The table has columns for 'Overall State', 'Comm Unit', 'ACM 0', 'Actuator Front Right', and 'Actuator Front Left'. A callout box on the right highlights a 'Fault' in the 'Actuator Back Right' section, specifically for 'Connection Port 4' and 'Haptic Actuator 2 AC218 SM0602'. A red box around the callout is labeled 'Fault Example'.

Overall State	Comm Unit	ACM 0	Actuator Front Right	Actuator Front Left
Fault (s)	OK	OK	OK	OK
Interface Index		0	0	0
Type	KCU-IP	ACM-II (Main)		
Configured Model Name			AC218 SM0602	AC218 SM0602
Orientation			Vertical	Vertical
Configuration Code		1020		
Serial (Interface)	00003623	21200212		
Serial (Actuator)			23521021	23468026
Supporting Axis			Roll, Pitch	Roll, Pitch
Stroke			34.50 mm	34.50 mm
Weight			0 N	0 N
Motor Temperature			34.1 °C	35.6 °C
Average Square Current			0 A²	0 A²
Instantaneous Motor Current			0.0 A	0.0 A
High Voltage Rail			160.2 V	160.8 V
Auxiliary Supply Voltage			15.1 V	15.1 V
Logic Voltage			4.9 V	4.9 V
Power Bridge Temperature			29.0 °C	26.3 °C
Position			-22.27 mm	-22.24 mm
Speed			-14 RPM	6 RPM
Maximum Speed			120 mm/s	120 mm/s
Maximum Acceleration			9804 mm/s²	9804 mm/s²
Encoder Type			Absolute	Absolute
ACM Motor Slot			Slot 0	Slot 1
Delay	0.0 ms	0.0 ms		
Intensity Level	0.0 dB	0.0 dB		
Spectrum		-0.0 dB		
Actuator Fault LED		OK		
Actuator Status LED		Park		
Effective Mode		Park		
Intensity Reset Mode		Disabled		

NOTE: See [Possible Faults and Corrective Actions](#) for possible causes and corrective actions.

5.2 D-BOX Adaptive Gaming Configurator

This application allows you to build, modify, and activate your Adaptive Gaming profiles. You can also share your favorite profiles with other D-BOX users by right-clicking on the profile and selecting the Export function.

The screenshot shows the 'D-BOX Adaptive Gaming Configurator' interface. The main window is titled 'Elden Ring (action adventure, gamepad)'. On the left, there is an 'Adaptive Profile Selector' with a search bar and a list of games. The main area shows 'Generic Controllers' (MS Mouse, KB Keyboard, GC Gamepad Controller) and 'Joystick Controllers' (None detected). Below, there are three sections for configuring haptic effects: 'Movement - Joystick', 'Action - Continuous', and 'Action - Button'. Each section has a 'Generator' dropdown, an 'Intensity' slider, and a 'Variation' slider. The 'Action - Continuous' section is currently selected, showing 'Shield Up' and 'Light Attack (1 Handed Axe)' effects.

5.3 D-BOX System Monitor Recorder

This is a useful tool for troubleshooting your haptic system. The System Monitor Recorder lets you export logs, helping our Support team diagnose and resolve issues:

STEP 1: Power off all ACMs by disconnecting their power cords.

STEP 2: Open the D-BOX System Monitor Recorder from the D-BOX Utilities folder and let it run in the background.

STEP 3: Power on the ACM(s).

STEP 4: Run the simulation or game software until the issue is reproduced.

STEP 5: Once the issue is reproduced:

a) Click **Save Recording** to save the recording file.



b) Click **Take Snapshot**.



c) Save both files using the default names to simplify the identification process.

STEP 6: Send both files by email to D-BOX Support.

5.4 D-BOX Stimuli Presenter

The D-BOX Stimuli Presenter is a keyboard-controlled application for sending basic signals to the haptic system, which is helpful for testing and demos.

```

D-BOX Stimuli Presenter
Initializing...
Started

Travel time: 1.0 s.
Ambiance and effect intensity: 0 dB
=== PRESENTER MENU ===

Roll/Pitch TRAVEL DIRECTION   Heave TRAVEL DIRECTION   TRAVEL DURATION
Left /|\ Right                Up
 [7] [8] [9] Forward         /|\                       [-] Decrease
<- [4] [5] [6]-> Center      arrows                     [+] Increase
 [1] [2] [3] Backward        \|\
                               \|\
                               Down

[T][Y] Gun effect (front)     [B] Boat ambiance        EFFECT INTENSITY
[G][H] Gun effect (back)     [C] Climb ambiance
[E] Explosion effect         [R] Rumble ambiance     [/] Decrease
                               [U] Decrease Frequency  [*] Increase
                               [O] Increase Frequency
[I] Sine Generator           [Q] Quit
[L] Stop ambiences
  
```

6. COMMUNICATION UNIT

The Communication Unit transmits the data from the haptic source to the first ACM in the chain.



CAUTION: Avoid connecting the Communication Unit to the USB port of a Windows computer before the D-BOX HaptiSync Center software suite has been installed. Although the application installs itself as soon as the Communication Unit is connected to the computer, it requires driver files to complete the installation process.

CAUTION: The KCU-1X works with D-BOX G5 Haptic Actuators and G3 FLEX ACMs. The (older) KCU-1P works with D-BOX G2, G3, and G3 FLEX ACMs. **Never** connect a KCU-1P or a KCU-1X to an ACM-I (G1).

The KCU-1X comes with a USB cable and an installation bracket. It has two ports: HAPTIC OUT and USB (powered).

The KCU-1P comes with a USB cable, an installation bracket, and a power supply. It has two ports (MASTER OUT and USB) and a power input jack.

PORTS / JACK	RECOMMENDED CABLE	COMMENTS
KCU-1X HAPTIC OUT or KCU-1P MASTER OUT Connect the Communication Unit to the ACM	Use the shielded CAT5E/6A cable provided included with your haptic system package.	<ul style="list-style-type: none"> If you do not use the provided cable, ensure to use a shielded CAT5E or CAT6A cable and that the RJ45 at each end features a metal jacket. The total length should be 100 ft. (30.5m) or less (Communication Unit to last haptic system). Connect one end of the cable to the OUT port of the Communication Unit. Connect the other end of the cable to the MAIN IN Port of the ACM.
USB Connect the Communication Unit to the computer	Use the provided USB cable to connect the Communication Unit to the computer.	<ul style="list-style-type: none"> Connect the USB-A end of the cable to the USB port of the computer. Connect the other end (USB-C for KCU-1X, USB-B for KCU-1P) to the USB port of the Communication Unit. If you are not using the provided USB cable, the total length of the USB cable you use must not exceed 6 ft (1.8m).
POWER (KCU-1P only)	100 – 230VAC, 50 – 60Hz, 0.63A Output: +48VDC	<ul style="list-style-type: none"> Always connect the power cable to a grounded receptacle.

6.1 Communication Unit Power Up

At power up, the front LED shows the status of the Communication Unit.

NOTE:

- *The KCU-1X is used with ACM G3 FLEX, G5 (using HB240 Haptic Bridges), and ACM G3 FLEX/G5 mixed systems).*
- *The KCU-1P is used with G2, G3 ACMs, and systems combining ACM G3 FLEX with older ACMs).*

Power up sequence

Red	<p>KCU-1X: No power present/USB not connected.</p> <p>KCU-1P: 48V-power present but no USB connection</p>
Orange	Connected to the computer USB port, drivers are installed. The unit is ready to operate.
Green	Active Motion

For more information on the LED status, refer to the [Troubleshooting section](#).

NOTE:

- *One KCU-1X can provide the haptic signal for a maximum of 7 daisy-chained ACMs G3 FLEX or 7 daisy-chained G5 Haptic Bridges.*
- *One KCU-1P can provide the haptic signal for a maximum of 20 daisy-chained ACMs G3 or 63 daisy-chained ACM G3 FLEX.*

7. ACTUATOR CONTROL MODULE (ACM)

7.1 ACM Families and Compatibility

There are multiple ACMs in the G3 architecture. This section covers the details for the ACM G3 FLEX.

If you have a system using an older version of our ACMs (G2 or G3), please refer to [Appendix B – G3 Haptic System Using Older ACM Versions \(ACM G3 or ACM G2\)](#).

If you have a system using G5 actuators as well, please refer to [Appendix C – Mixing G5 and G3 Haptic Systems](#).

In G3 architecture, the ACMs are only compatible with a G3 actuator (motor and mechanics). Components of different generations are not compatible with each other.

7.2 Voltage Selection

Set the ACM G3 FLEX voltage according to your region's power requirements using the selector switch next to the power connector.



120V ↔ 230V

7.3 ACM Door Installation (6-inch travel haptic systems only)

The actuators come packaged separately from the ACM for 6-inch travel haptic systems. Connect the actuator(s) and secure the access door using the provided Quadrex screws. If using a single actuator with the ACM, install the actuator door using the provided Quadrex screws.

One actuator connected (to the ACM)

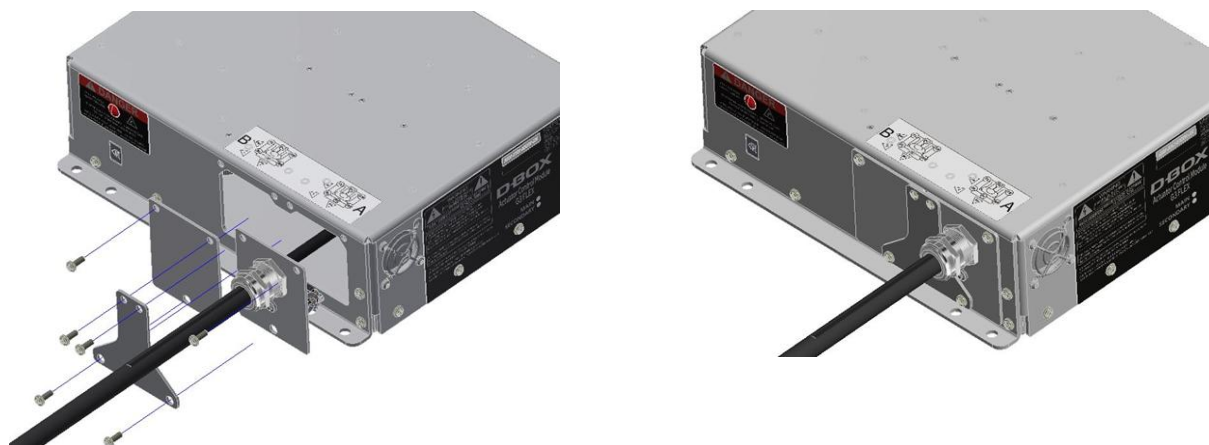

Two actuators connected



7.4 ACM Connections (with KCU-1X Communication Unit)

Depending on the ACM position in the system, it is programmed as:

- **MAIN:** First ACM in a haptic system
- **SECONDARY:** All following ACMs

The last MAIN and SECONDARY ACM(s) in the chain must always be terminated using a one-foot, shielded CAT5E or CAT6A cable, connecting from NEXT to END ports of ACM.

NOTE: The ACM ports have been renamed on the ACM G3 FLEX; however, they are in the same order as on the ACM G3.

ACM G3	ACM G3 FLEX
IN	IN
OUT	NEXT
END	END
NEXT (OPTIONAL)	SECONDARY
KINEREMOTE	REMOTE

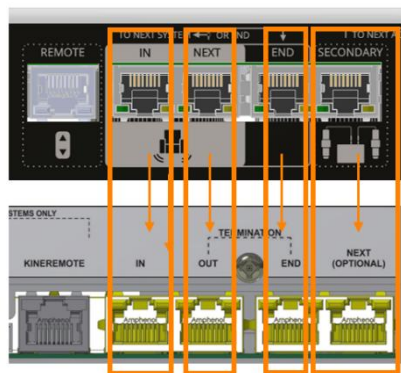

The following are typical ACM configurations for a haptic system.

1 ACM G3 FLEX (1 or 2 actuators)

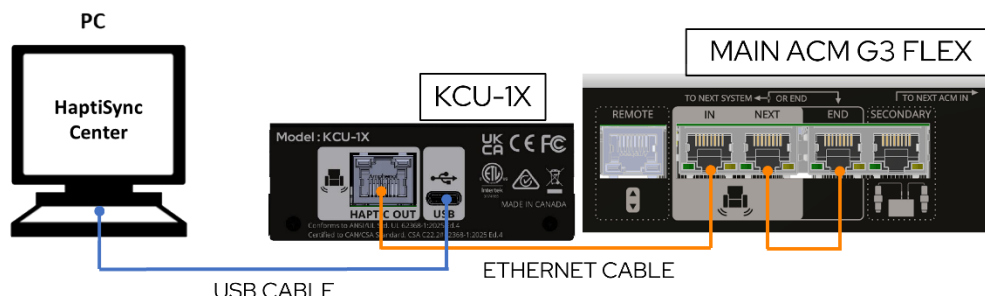

2 ACMs G3 FLEX (3 or 4 actuators)

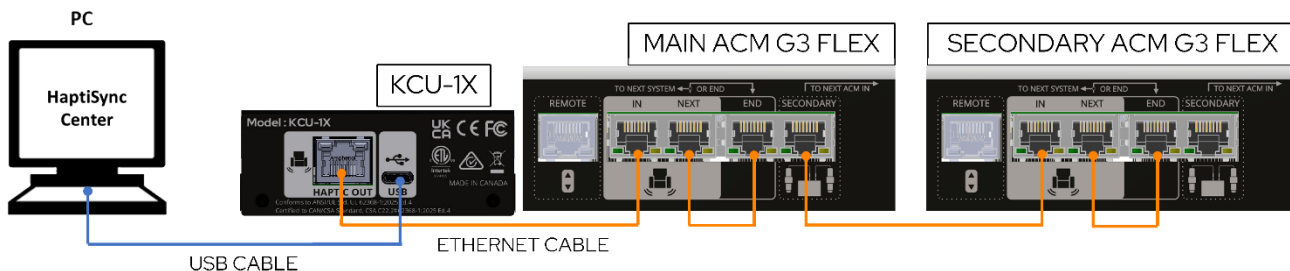

4 ACMs G3 FLEX (7 or 8 actuators)

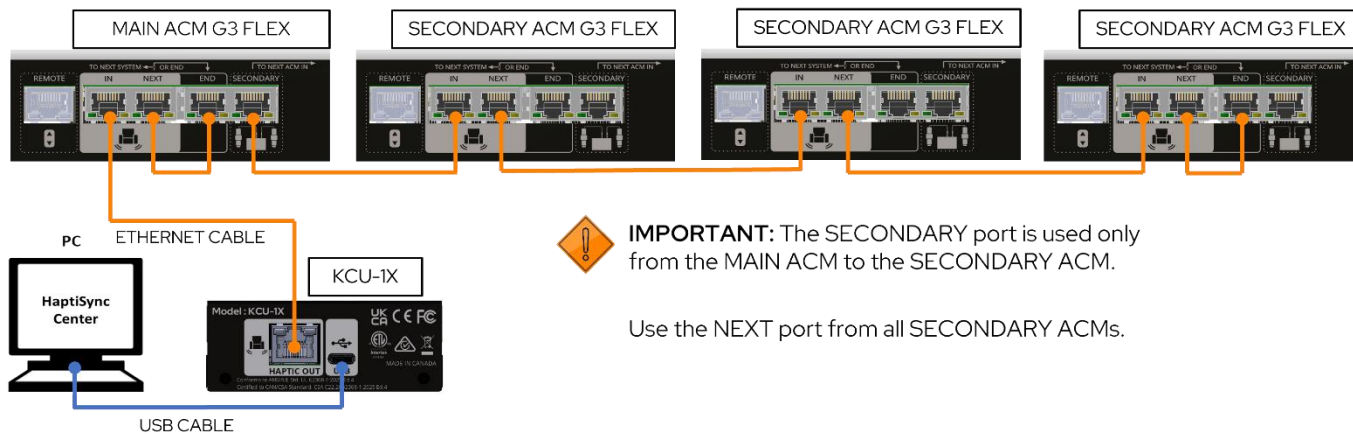

The following example shows three D-BOX haptic systems using two ACM G3 FLEX each. In this case, the three systems are daisy-chained.

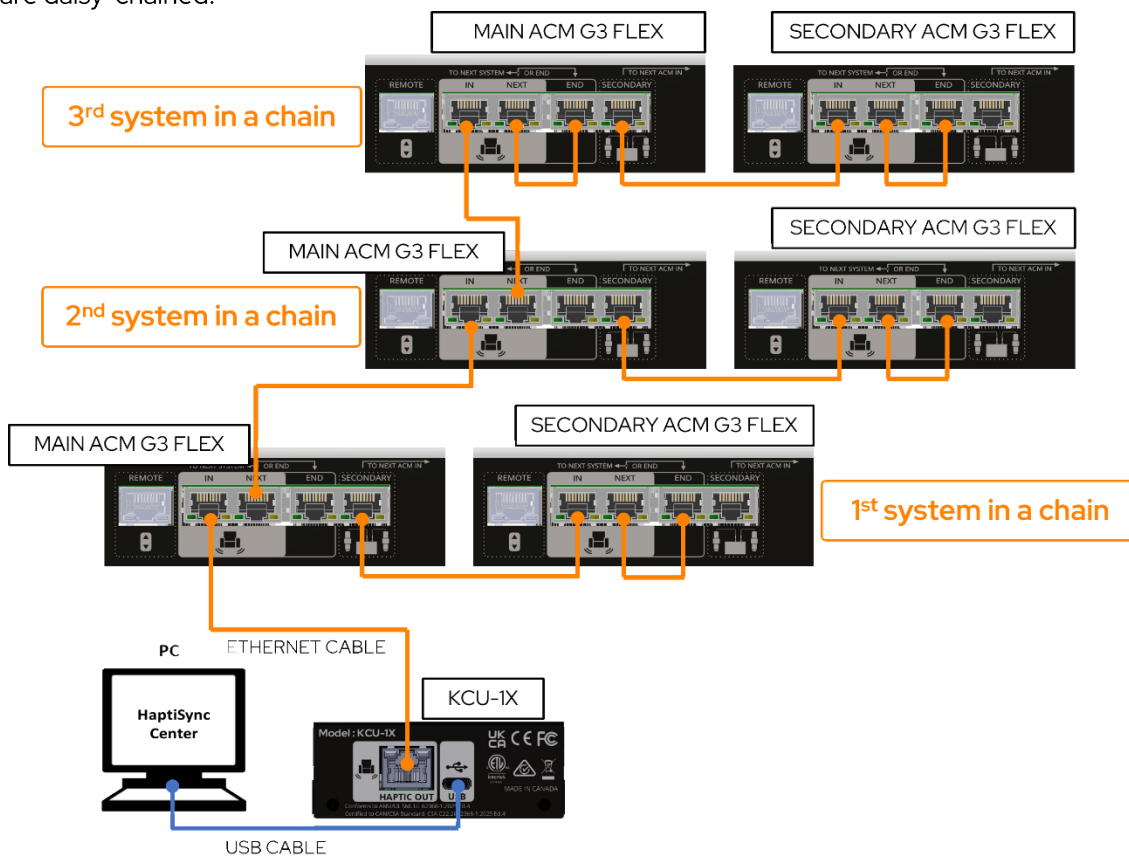

8. ACTUATORS

8.1 Maximum Axial Load

The following table shows the maximum axial load for each actuator.

TRAVEL	ACTUATOR MODEL (mechanics name)	MAXIMUM AXIAL LOAD lbs.	MAXIMUM AXIAL LOAD ¹ N _{D-BOX}
1.5 in	250HD (AC10)	250	1900
	400HD (AC10)	400	2400
	250i (AC218)	250	1900
	400i (AC218)	400	2400
3.0 in	250i-3 (AC231)	250	1900
	400i-3 (AC231)	400	2400
6.0 in	500HD-6 (AC360)	500	2800

¹You can find the reference to the maximum axial load in the Haptic Output tab of D-BOX HaptiSync Center, under Diagnostics. The Newton units are a reference to the load perceived by each motor but cannot be converted into actual Newtons; therefore, D-BOX uses a proprietary, Newton-based measurement index.

IMPORTANT:

- Make sure that the weight on the platform does not exceed the maximum supported weight.
- Make sure that the weight is evenly distributed among the actuators of the platform (as centered as possible).

8.2 Weight Distribution

Each actuator has an individual maximum payload. When integrating a haptic system on a platform, it is recommended to balance the **center of gravity** (C.G.) of the platform to ensure **each actuator supports an equal load**. The following figures show equal weight distribution with two, three, or four actuators.

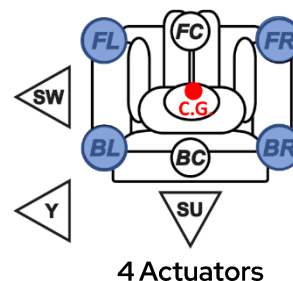
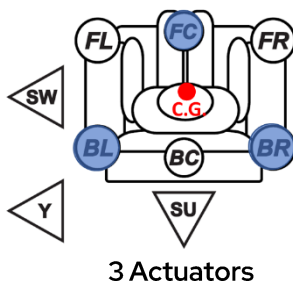
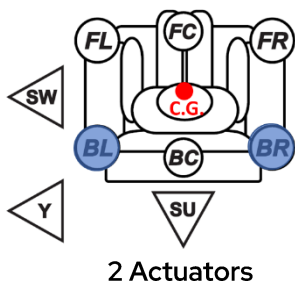

8.3 Actuator Acceleration

The D-BOX haptic system can produce a 1G acceleration or greater. However, to avoid the risk of injury or damage to the equipment, it is recommended to calibrate the haptic system to produce a maximum of 1G, using the intensity sliders found in D-BOX HaptiSync Center. An acceleration above 1G can cause the platform to jump. Jumping can be observed when the actuator lifts off from the ground. The following figures show a piston jumping in its cup:

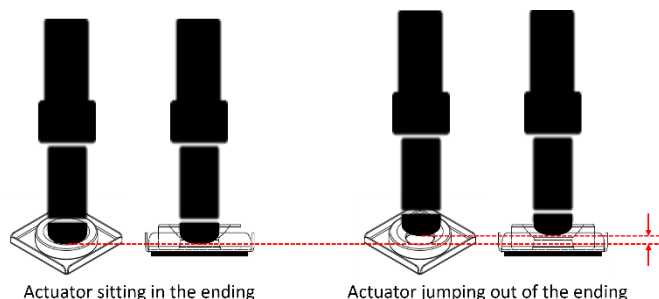

The shock of a piston falling back down in its cup reverberates on the top bearing of the piston, which takes the hit to protect the motor. As wear progresses, the bearing becomes noisier, reducing the service life of the ball nuts and screw. Avoid having the actuator jump in the cup.

This behavior is typical when running the platform with no or light weight. There are no guidelines for minimum weight. It is highly dependent on the actuator position, haptic code, simulator weight, simulator structure, and weight distribution.

8.4 Distance Between Actuators

Respect the minimum distance between actuators for adequate movement of the platform. Measure the distance from a **square surface enclosing all actuators** (see example below). Respecting the spacing guidelines ensures proper interaction of the haptic system with the actuators, as well as proper lateral force transfer.

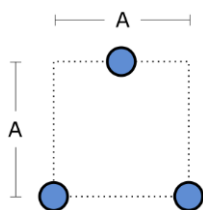

TRAVEL	MINIMUM SPACING BETWEEN ACTUATORS (A)
1.5 in	14 in [356 mm]
3.0 in	24 in [610 mm]
6.0 in	36 in [914 mm]

8.5 Actuator Alignment

When using two actuators and a pivot, or three actuators, install them in an isosceles triangle pattern.

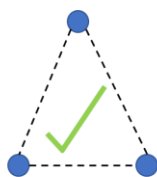

Adequate actuator integration

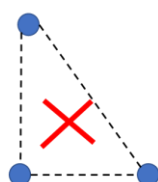

Inadequate actuator integration

When using four actuators, install them in a square or rectangular pattern.

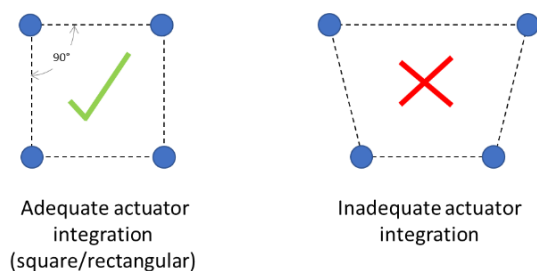

8.6 Actuator Levelling

During installation, the actuators must always remain straight to limit radial loading. Radial loading could result in premature wear of the actuators.

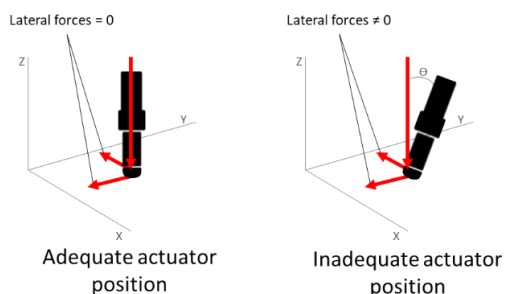

8.7 Level Surface

All actuators must be level on the same flat surface for optimal operation. Different levels could result in premature wear of the actuators.

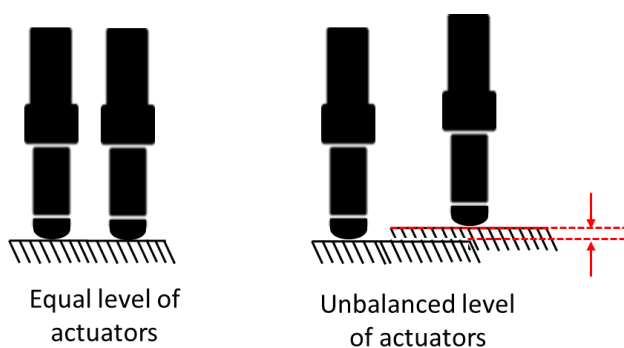

8.8 Usage of 6-inch Actuators for Lateral Motion

The 6-inch actuator has a play (movement) of approximately 1 mm, inherent to its design. This play can be felt when used in lateral motion (yaw, surge, and sway) and can impact the realism of the simulation.

NOTE: *The play does not interfere with usage of such a system in general simulation but has been reported as problematic by some sim-racing professionals.*

9. ACTUATOR ENDING INSTALLATION (OPTIONAL)

G3 actuators can be installed with captive or non-captive endings. Captive endings are required when you want to bind the actuators to the floor or a sub-frame.

9.1 Non-captive Ending Installation (Optional)

Once the actuators are installed on your platform, lower the actuators (and pivot for 2-actuator configuration) into the (optional) sliding cup. Also ensure the metal plate is placed under the cup. Actuators and pivots must be centered in their respective ending.

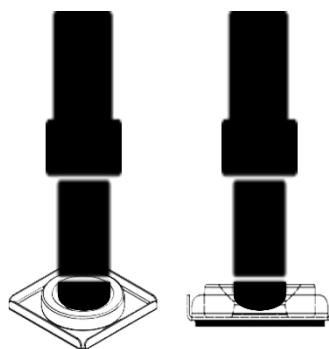

9.2 Captive Ending Installation (Optional)

Some platforms may require the use of an actuator ending that binds the actuator to the floor or a frame. The D-BOX captive ending (ball joint) allows proper actuator movements.

There are two captive ending models:



OEM: Use with 6 in (AC360) actuators.



OEM LITE: Use with 1.5 in (AC218, AC10) and 3 in (AC231) actuators.

The D-BOX captive ending is a two-component assembly.

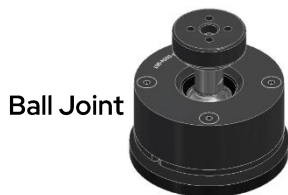

Ball Joint



Spacer Retainer

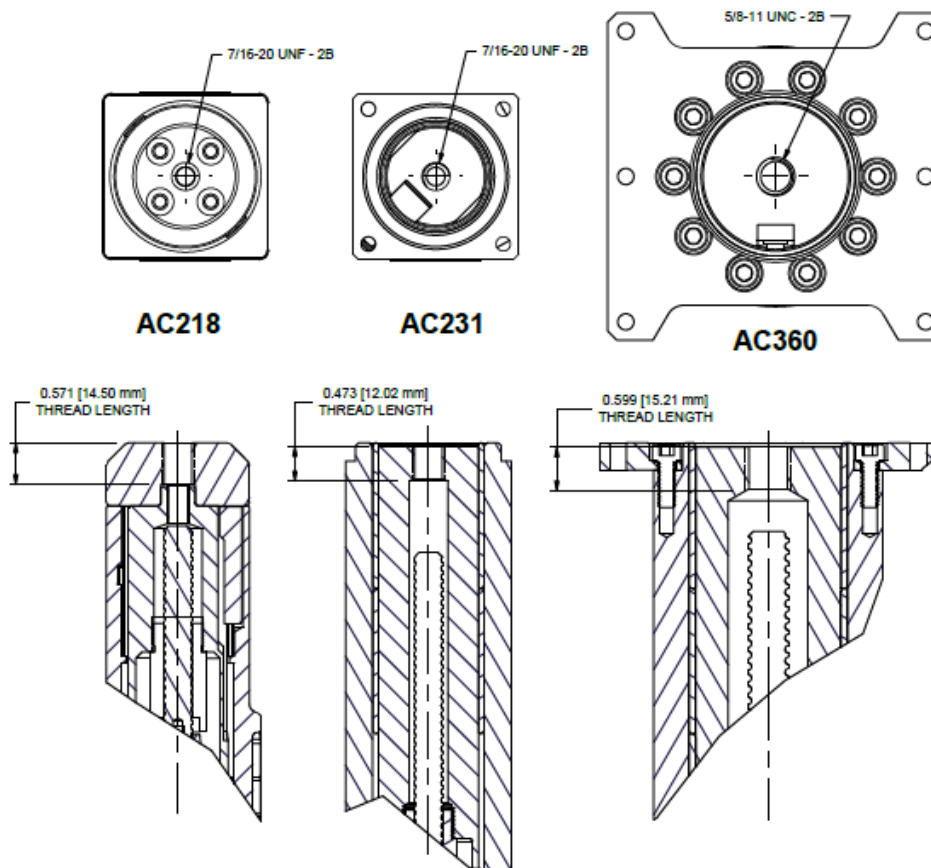

CAUTION: Respect the orientation of the Spacer Retainer to avoid any damage to the haptic system.

The thread of the captive endings for each actuator is as follows:



Spacer Retainer

The Spacer Retainer allows specific movements of the ball joint on both x and y axes, thus eliminating any constraints during the movement of the platform. There are 3 models of Spacer Retainer. All Spacer Retainers can be fitted on any model of ball joint.

-  0 axis Allowing no movement on x or y axis.
-  1 axis Allowing movement only on one axis (x or y).
-  2 axes Allowing movement on two axes (x and y).

CAUTION: Respect the orientation to avoid any damage to the components of the platform.

Spacer Retainer Configurations

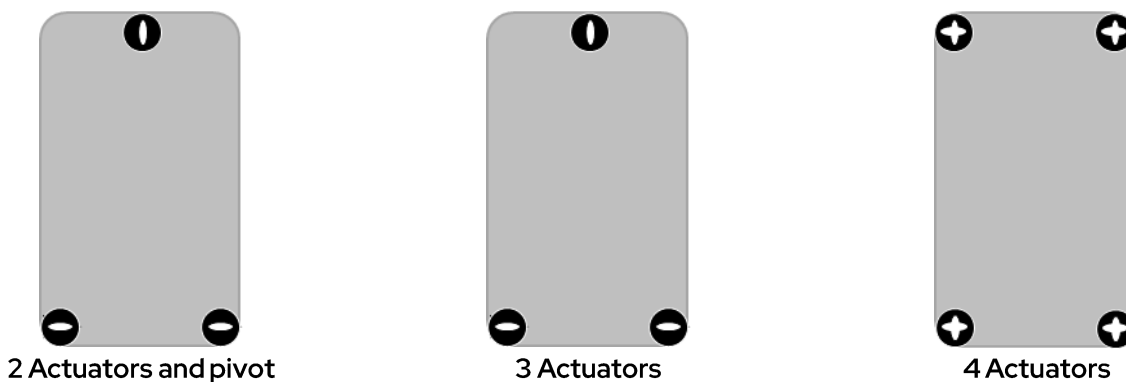

To help with positioning, "OUTWARD" is marked on its top surface.

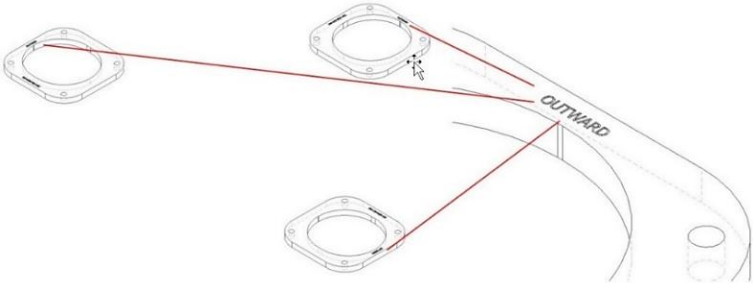

NOTE: The Base Plate (included with the Spacer Retainer kit) must be installed at the bottom of the assembly. This allows the captive ending to slide properly.

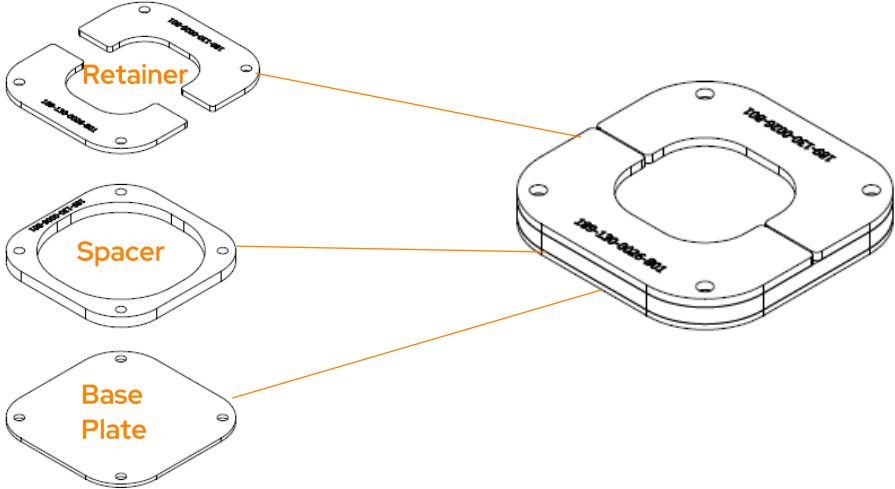

2 or 3 Actuators

Captive endings must be installed off-center from the Spacer Retainers with the gap at the OUTWARD marker.

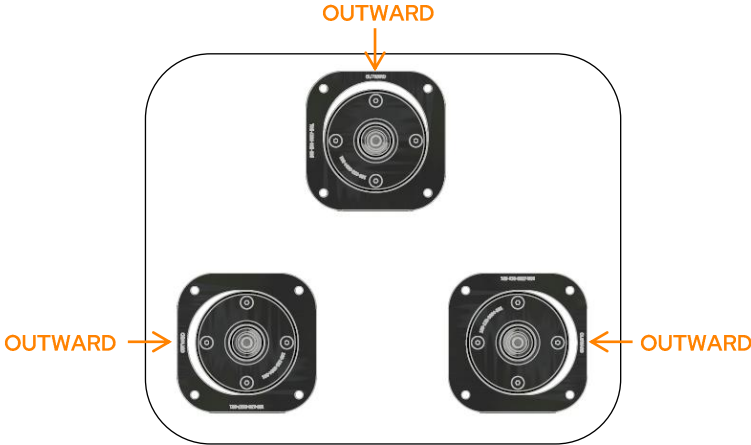

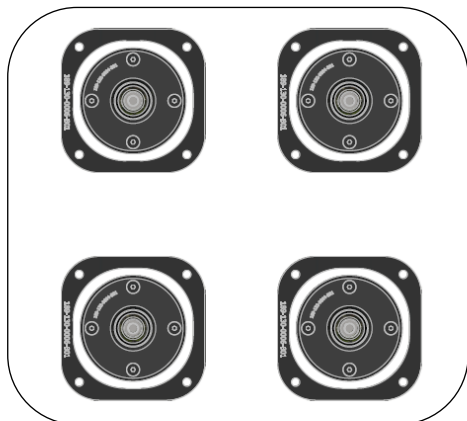

4 Actuators

Captive endings must be installed in the middle of the Spacer Retainers.



Tools Required

	<p>Short Hex Key</p> <ul style="list-style-type: none"> • 4mm (for AC218 OEM, AC218 LEG, AC218 captive ending) • 5mm (for AC218 anchor, AC218 luxury) • 6mm (for AC211 MFX-ILC) • 1/8" (for AC7i) • 3/8" (for AC7 delrin, AC7v-ABS, AC231, AC211 ABS, AC10 Straight, AC360 non-ABS) • 3/16" (for AC7r) • 1/2" (for AC360 ABS) • 9/64" (for AC231...)
	<p>5/8" wrench</p>
	<p>Adjustable Wrench or Wrench:</p> <ul style="list-style-type: none"> • 1/4" wrench (for AC7, AC231) • 1 3/8" wrench (for AC211) <p>NOTE: AC218, AC10, AC360 do not have a flat spot.</p>

The following are installation instructions for (optional) D-BOX captive endings/ball joints. Ensure that all parts are clean before starting.

1.5-inch Actuator - AC218

CAUTION: Never operate the AC218 actuator without the tip/ending connector installed. Operating the AC218 actuator without the tip leads to irreparable damage to the actuator.



Removal

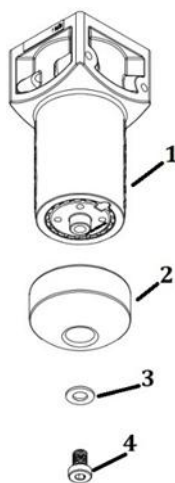



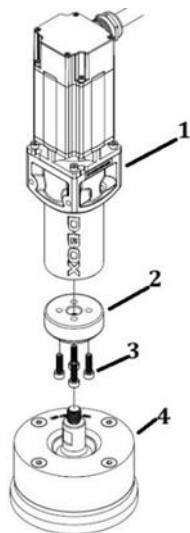

1. Pull the piston out of its body until you can access the flats on both sides of the shaft.
2. Position the wrench around the flat spot to hold the piston while performing the next step and to prevent rotation.
3. Unscrew the bolt (4) with the 1/2" Hex key and remove washer (3) and tip (2) from the actuator (1).

Installation



1. Apply Threadlocker Loctite 263 to the threaded section of bolts (3) and ball joint (4).
2. Install the AC218 adaptor (2) on the actuator (1) with bolts (3). Torque the bolts to 50 lbf-in (6 N-m).
3. Screw the threaded section of the ball joint (4) in the actuator (3). Use a torque wrench with a 5/8" crowfoot socket to tighten the ball joint (4) in the actuator. Torque to 170 lbf-in (20 N-m).

1.5-inch Actuator - AC218

	<ol style="list-style-type: none"> 4. Place the spacer (5) at its required location. 5. Ensure that the holes for the spacer are aligned with the holes of the base plate (6). 6. Slide the retainers (7) onto the spacer (5) and in the slot on the ball joint
	<ol style="list-style-type: none"> 7. Slide the retainers (7) onto the spacer (5) and into the slot on the ball joint assembly.
	<ol style="list-style-type: none"> 8. Align the holes of the retainer, spacers, and base plate. Use 5/16" bolts to tighten the assembly to the floor. <p>NOTE: <i>The way the ball joint is anchored to the floor is the same for all actuators (1.5", 3", and 6").</i></p> <p> Never operate the actuator without the back plate installed. This may lead to malfunction or damage to the actuator.</p>

3-inch Actuator - AC231

Removal

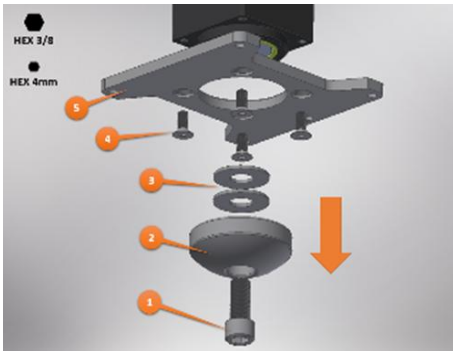
	<ol style="list-style-type: none"> 1. Pull the piston out of its body until you can access the flats on both sides of the shaft. 2. Position the wrench around the flat spot to hold the piston while performing the next step and to prevent rotation. 3. Unscrew bolt (1) with the 3/8" Hex key and remove the tip/ending connector (2) and washers (3) from the piston. Unscrew the bolt (4) with the 4mm Hex key and remove the H-Bracket (5) (optional) from the actuator.
---	--

3-inch Actuator – AC231

Installation



1. Add Threadlocker Loctite 263 to the threaded section.
2. Screw the threaded section into the actuator. Use a torque wrench with a 5/8" crowfoot socket to tighten the ball joint assembly in the actuator. Torque to 170 lbf·in (20 N·m).



3. Place the spacer (1) at its required location.
4. Ensure that the holes for the spacer are aligned with the holes of the base plate (2).



5. Slide the retainers (3) on spacer (1) and in the slot on the ball joint assembly.



6. Align the holes of the retainer, spacers, and base plate. Use 5/16" bolts to tighten the assembly to the floor.

NOTE: *The way the ball joint is anchored to the floor is the same for all actuators (1.5", 3", and 6").*

6-inch Actuator – AC360

Removal

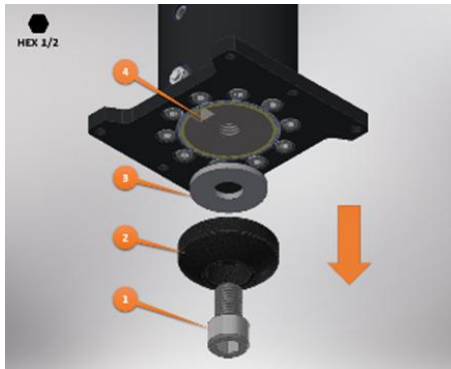

1. Pull the piston out of its body until you can access the flats on both sides of the shaft.
2. Position the wrench around the flat spot to hold the piston while performing the next step and to prevent rotation.
3. Unscrew the bolt (1) with the 1/2" Hex key and remove the tip/ending connector (2) and washer (3) from the piston (4).

Installation

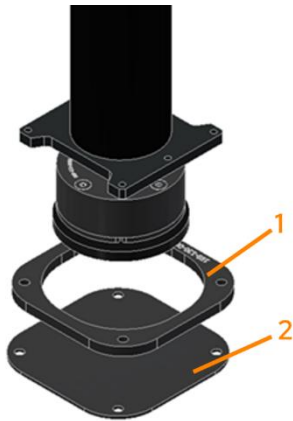

1. Place the spacer (1) at its required location.
2. Ensure that the holes for the spacer are aligned with the holes of the base plate (2).



3. Slide the retainers (3) onto the spacer (1) and into the slot on the ball joint assembly.

6-inch Actuator – AC360

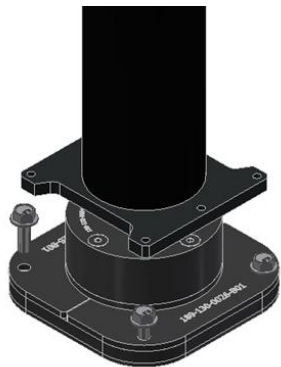

4. Align the holes of the retainer, spacers, and base plate. Use 5/16" bolts to tighten the assembly to the floor.

NOTE: *The way the ball joint is anchored to the floor is the same for all actuators (1.5", 3", and 6").*

10. BRACKET INSTALLATION

D-BOX offers three types of brackets: “H”, “L” and “U”-shape that can be bought (optional) for your haptic system. The screws to attach your actuator to the bracket are included with your haptic system; however, you need to provide the screws to mount the brackets to your platform.

The following table lists the available brackets per type of actuator.

TRAVEL	ACTUATOR MODEL (mechanics name)	H-Bracket	U-Bracket	L-Bracket
1.5 in	250HD (AC10)	✓	-	-
	400HD (AC10)	✓	-	-
	250i (AC218)	-	✓	✓
	400i (AC218)	-	✓	✓
3.0 in	250i-3 (AC231)	✓	✓	✓
	400i-3 (AC231)	✓	✓	✓
6.0 in	500HD-6 (AC360)	✓	-	-

10.1 U-Bracket Installation

First, install the U-Bracket to your platform and then attach the actuators to the brackets using the screws provided.

3 in Actuator/AC231

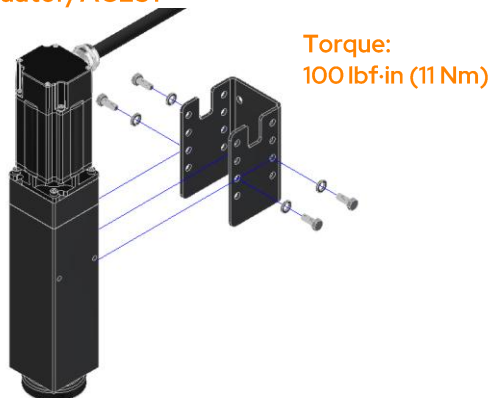

1.5 in Actuator/AC218

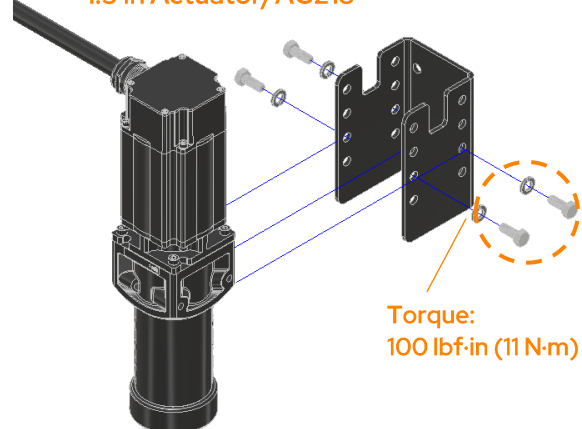

NOTE: Screws to attach the bracket to your platform are not included.

10.2 L-Bracket Installation

First, install the L-Bracket to your actuator using the provided screws and then attach the assembly to your platform.

3 in Actuator/AC231

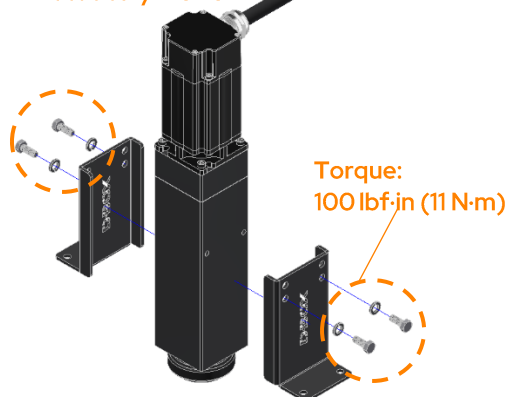

1.5 in Actuator/AC218

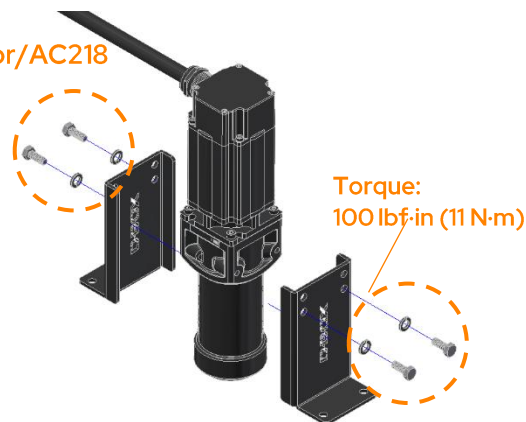

NOTE: Screws to attach the bracket to your platform are not included.

10.3 H-Bracket Installation

H-Bracket for 1.5 in HD Actuator - AC10

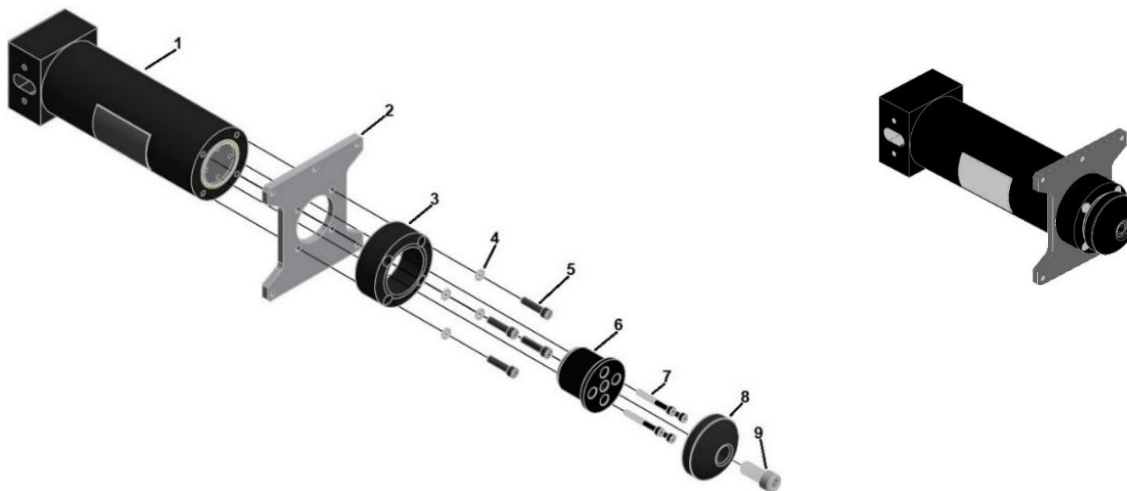

NOTE: Apply one drop of Loctite 243 blue thread locker onto the bolts (5), (7), and (9) before installation.

1. Align holes on H-plate (2) with the holes on the housing (1), then align the holes on the stop (3) with the holes on the H-plate (2) and then secure it with the lock washers (4) and bolts (5). Torque the bolts (5) to 100 lbf-in (11 N-m).
2. Align the holes on the end piston adapter with the holes on the piston end and secure the end piston adapter (6) with bolts (7). Torque the bolts (7) to 40 lbf-in (5 N-m).
3. Secure the tip/ending connector (8) to the end piston (6) with bolt (9). Torque the bolt (9) to 130 lbf-in (15 N-m).

H-Bracket for 3in Actuator - AC231

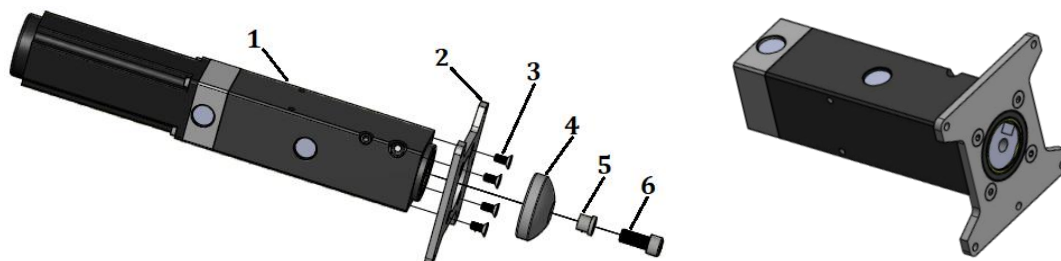

1. Place the H-Bracket (2) on the end of the piston body (1) with the screw holes aligned.
2. Apply Loctite 243 (blue) thread locker into the four blind holes (2) on the piston body.

NOTE: Apply the thread locker just before the bottom of the blind holes.

3. Use a 5mm bit to secure the H-Bracket plate to the piston body with the screws (3) (item 4, M6 X 1.0 X 14 mm), then tighten the screws to a torque of 100 lbf-in (11 N·m).
4. Install the tip/ending connector (4) with the spacer (5) and bolt (6).

H-Bracket for 6in Actuator - AC360

NOTE: There are two models of H-Brackets: one with seven mounting holes, and one with 10 mounting holes.

The procedures are the same for both models. Only the 10-hole model is shown here.

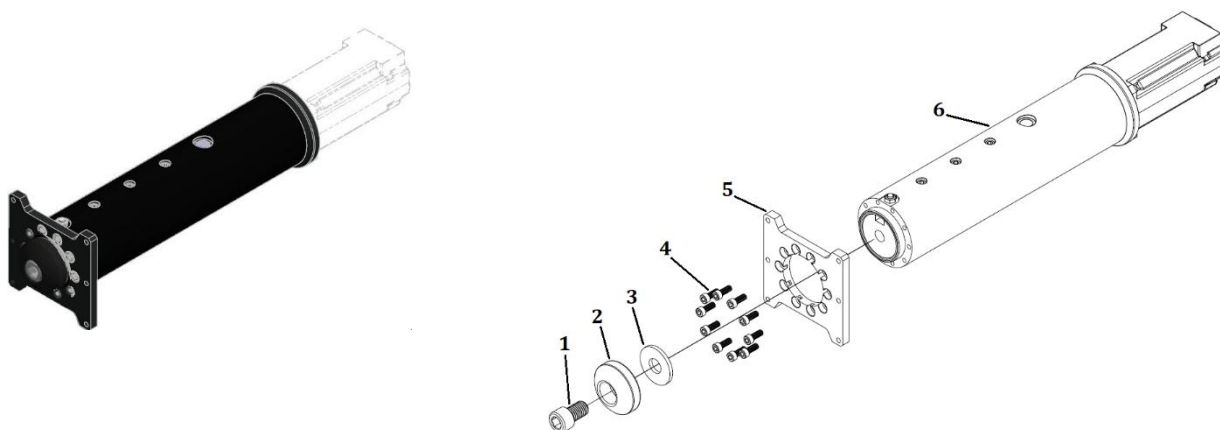

1. Place the H-Bracket (5) on the end of the piston body (6) with the screw holes aligned.
2. Apply Loctite 243 (blue) thread locker into the ten blind holes on the piston body (6).

NOTE: Apply the thread locker just before the bottom of the blind holes.

3. Use a 5mm bit to secure the H-Bracket to the piston body with screws (item 4, M6 X 1.0 X 14 mm), then tighten the screws to a torque of 100 lbf-in (11 N·m).
4. Install the tip/ending connector (2) with washer (3) and bolt (1).

11. HAPTIC SYSTEM OPERATION

Power on your haptic system. The actuators perform a homing sequence, going all the way up, all the way down, and then center. This is normal behavior.

12. TROUBLESHOOTING

This section contains step-by-step instructions to troubleshoot your G3 haptic system. If you need additional support, contact your reseller support team or the D-BOX Technical Support team if your system was bought directly from D-BOX.

12.1 Initial Troubleshooting Steps

STEP 1: Verify that the haptic system, the Communication Unit, and computer are powered on. If the status LED is orange or red, you are required to take action. Refer to [Troubleshooting with Communication Unit LED Statuses](#) for details.

STEP 2: Verify that all ACMs are set to [your country/region's voltage](#).

STEP 3: Make sure your haptic system is connected to a grounded electrical outlet. If you must use an extension cable, use a 3-wire cable with properly grounded plugs. **Do not connect to a circuit with a GFI breaker.**

STEP 4: Check your haptic system's connection to ensure you are connected to the right ports, then verify that all termination loops are closed, when applicable. The last MAIN ACM and SECONDARY ACM must be terminated with a shielded CAT5E or CAT6A cable.

STEP 5: Make sure that the USB and network cables are firmly plugged in. Always use the original USB cable supplied with the KCU-1X. Other USB cables may not be compatible. All network cables must be shielded CAT5E or CAT6A. It is strongly suggested to use the network cables supplied with your haptic system.

STEP 6: Do a visual inspection of your system to ensure that nothing prevents the haptic system from moving properly. Power cords and network cables must be secured and out of the actuators' path.

STEP 7: Validate your global settings in the Haptic Output tab of D-BOX HaptiSync Center. Ensure that the haptic switch is set to ON and that your system is not muted.

12.2 Reinitiate/Reset Haptic System

STEP 1: Reboot your computer.

STEP 2: Power off the haptic system by unplugging the ACMs and Communication Unit (power cord for the KCU-1P, USB cable for the KCU-1X). Wait for at least 60 seconds, then restore power to the equipment. The platform performs its homing sequence by going up, down and then into the middle position.

NOTE: If the system does not go through its homing sequence, open D-BOX HaptiSync Center, navigate to the Diagnostics tab in the Haptic Output tab and check for alarms (see [Possible Faults and Corrective Actions](#)).

STEP 3: Reset all the global settings—the Haptic Settings and Advanced Configuration drop-downs in the Haptic Output tab, under Settings:

SETTING	VALUE
Haptic Settings	
Mute Haptics	OFF
Link Both Intensity Sliders	OFF
Movement Intensity	0 dB (full)
Vibration Intensity	0 dB (full)
Advanced Configuration	
Output Buffer Latency	0 ms
Platform Optimization	Automatic Detection
Idle Position	Park
Actuator Layout Rotation	None*
Actuator Stroke	Automatic Detection

*Unless using a G5 Motion Platform (Mercedes-Benz or Mercedes-AMG) for Sim Racing.

STEP 4: Reset the specific motion code settings for the game you are using. If you are playing a game using the D-BOX Coded Gaming mode, select your game from the Library and click **Haptic Settings & Profile Selection**. The Global Parameters tab and the Motion Profile Editor appear in the new window. From the Motion Profile Editor tab, reset all the motion settings.

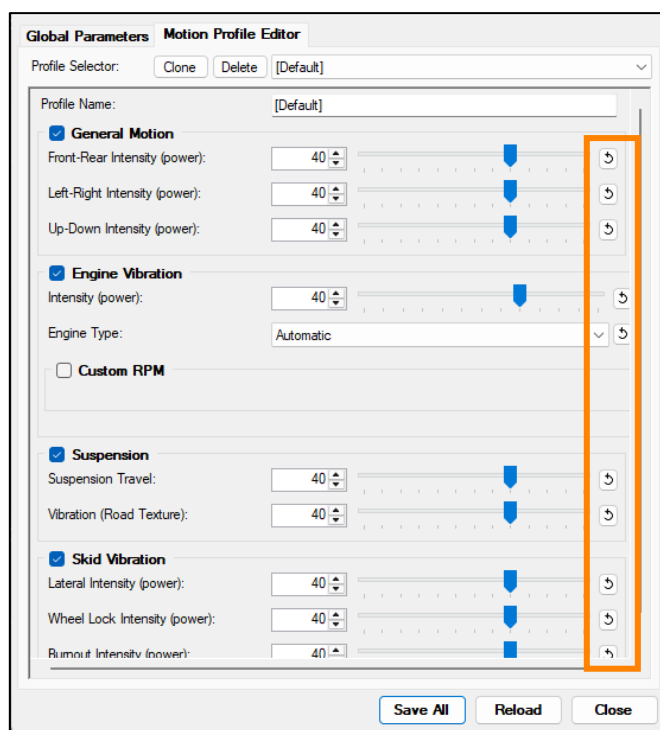

12.3 Update Software and Firmware

STEP 1: Make sure you have the latest version of D-BOX HaptiSync Center installed. Click the ^ icon, located to the left of the System Tray icons, to open the expanded tray. Right-click the D-BOX icon, then select **Check for Updates**.

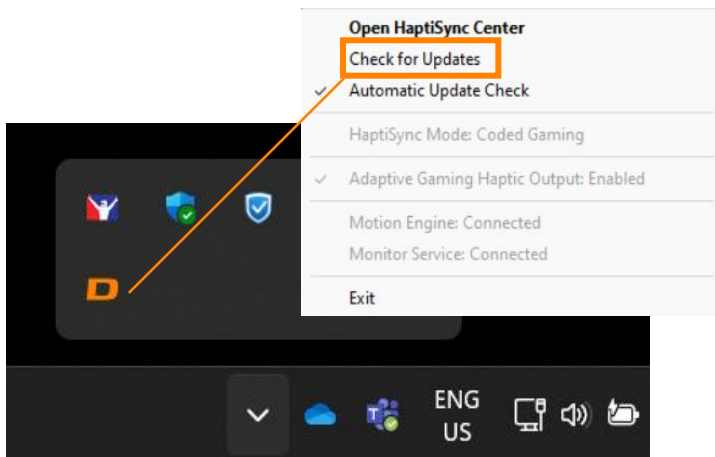

STEP 2: Ensure your firmware is up to date using D-BOX System Configurator (from the [System Configurator](#)'s Firmware Update tab, click **Refresh Firmware Status**).

12.4 Troubleshooting with Communication Unit LED Statuses

This section covers the status LED of the Communication Unit.

NOTE:

- The **KCU-1X** is to be used with D-BOX G5 Haptic Actuators (via HB240 Haptic Bridges) and ACM G3 FLEX.
- The (older) **KCU-1P** is to be used with D-BOX G2, G3 ACMs, and with systems combining any of those ACMs with an ACM G3 FLEX.

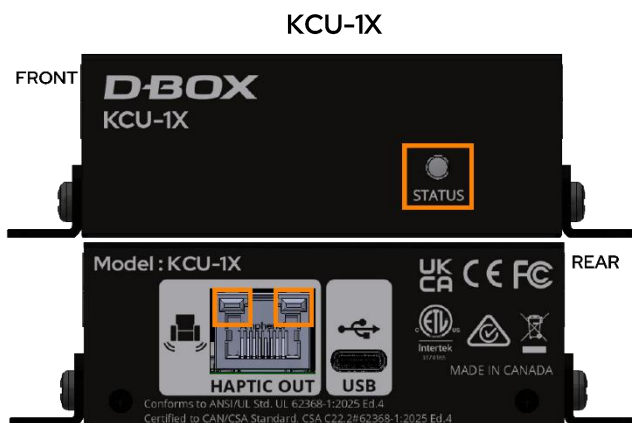

LED Statuses

Front Panel		
LED COLOR	STATUS	SOLUTION
OFF	Communication Unit is not powered	KCU-1X: Make sure the USB cable is properly connected. KCU-1P: Make sure the power supply is properly connected.
Red	No USB connection is detected	Check that the USB cable is properly connected. Make sure you have the latest version of D-BOX HaptiSync Center installed. Make sure you are using the original USB cable provided with the Communication Unit.
Orange	Connected to the PC USB port. The unit is ready to operate, but no haptic data received yet.	N/A
Green	The device is operational and is receiving haptic data (or silence data).	N/A

Rear Panel		
RJ45 LED	STATUS	SOLUTION
Green ON	Communication Unit transmitting	N/A
Yellow ON	Communication Unit receiving data	N/A

12.5 Troubleshooting Hardware Issues (D-BOX HaptiSync Center)

The Haptic Output tab of HaptiSync Center has the Status and Diagnostics tabs to assist with troubleshooting.

STEP 1: Check the indicators under the Status tab—they should be green. A red dot indicates a faulty component.

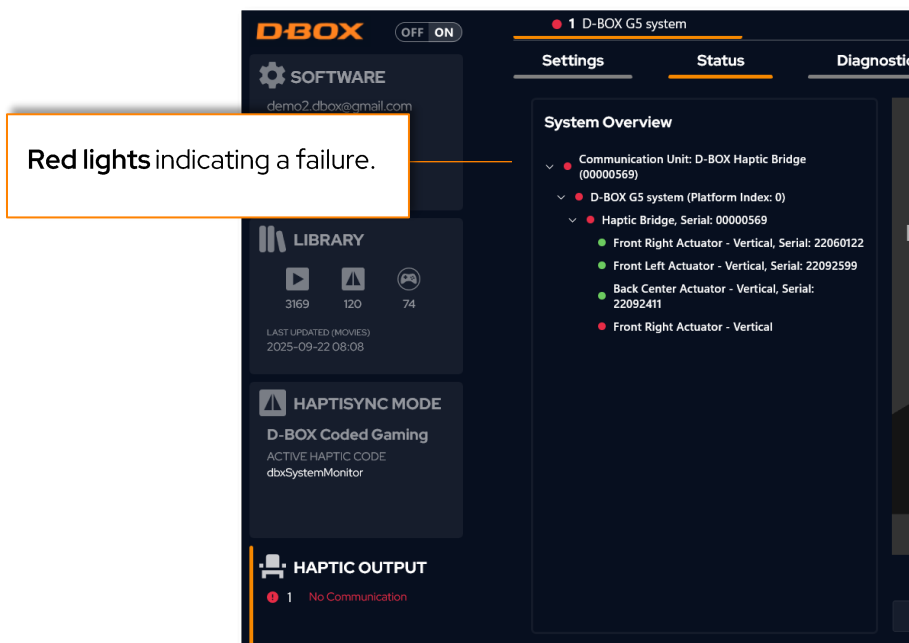

NOTE: Additional functions are available via buttons at the bottom right:

- **Start Haptic System:** Generates movement and vibration using a preset pattern. Useful for testing hardware–software communication.
- **Identify Actuators:** Sends a haptic “knock” to each actuator sequentially with on-screen identification, which helps verify correct actuator positioning.
- **Reset Unit:** Reset all your actuators to neutral. The platform will perform a homing sequence.

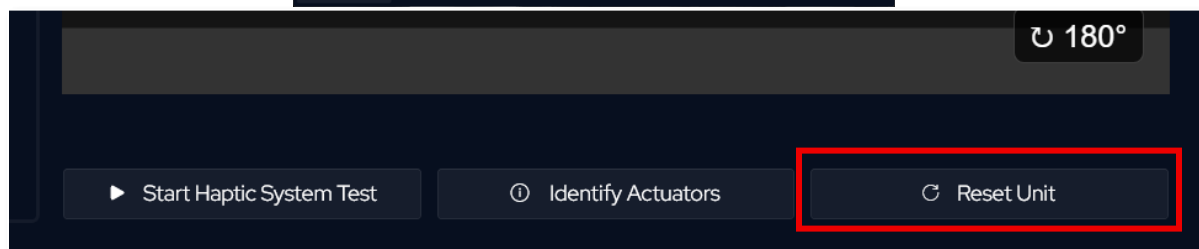
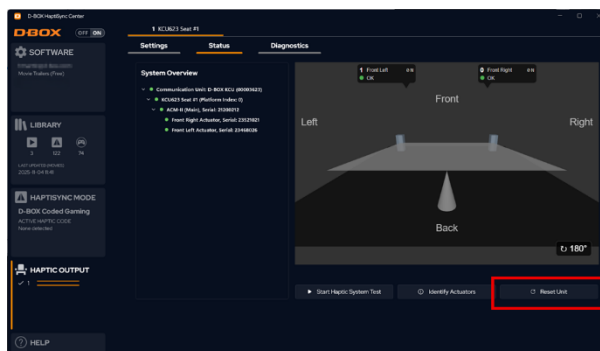

STEP 2: Under the Diagnostics tab, check the real-time condition of the haptic system. When a component fails, related information appears in red.

Fault

1 HB501 Seat #1						
Settings	Status	Diagnostics				
	Comm Unit	ACM 0	Actuator Front Right	Actuator Front Left	Actuator Back Left	Actuator Back Right
Overall State	OK	OK	OK	OK	OK	Fault
Fault (s)						Connection Port
Interface Index		0	1	2	3	4
Type	Haptic Bridge	Haptic Bridge	Haptic Actuator	Haptic Actuator	Haptic Actuator	Haptic Actuator
Configured Model Name			AC218 SM0602	AC218 SM0602	AC218 SM0602	AC218 SM0602
Orientation		Vertical	Vertical	Vertical	Vertical	Vertical
Configuration Code		10774	10774	10774	10774	10774
Serial (Interface)	00000501	00000501	00001873	00001764	00001988	00001411

STEP 3: See [Possible Faults and Corrective Actions](#) for possible causes and corrective actions.

12.6 Possible Faults and Corrective Actions

This is a list of faults you can find under the Diagnostics tab of the Haptic Output tab, including causes and corrective actions.

FAULT	CAUSES	CORRECTIVE ACTIONS
<p>ACM Communication Lost Fault</p>	<p>Power and/or network cable disconnected.</p>	<p>Make sure the power, USB, and network (if applicable) cables are securely plugged in.</p> <p>Inspect the entire length of the network cable for obvious signs of damage.</p> <p>Make sure your ACM is connected to a grounded electrical outlet.</p> <p>NOTE: <i>Do not use adapter plugs or remove the grounding prong from cables. If you must use an extension cable, use a 3-wire cable with properly grounded plugs.</i></p>
<p>Actuator Hard Fault</p>	<p>Something may be blocking the actuator. This is a Hard fault.</p> <p><i>The faulty actuator is immediately deactivated, and all other actuators go to their lowest position.</i></p>	<p>Check if there is anything blocking the travel of the actuator.</p> <p>Power off the haptic system, support your platform to gain access to the actuator piston and slowly pull it out of its body until the entire piston is out, and then slowly push it back in.</p> <p>If the error persists, replace/arrange to repair the faulty actuator.</p>
<p>Bridge Temperature Sensor Fault</p>	<p>This error can be triggered by starting the haptic system when the temperature is too low.</p> <p>The internal power bridge sensor is defective.</p>	<p>Make sure your haptic system is running in a temperature range between 0 to 40°C.</p> <p>Make sure there is sufficient airflow around the actuator.</p> <p>If the problem persists, replace/arrange to repair the faulty actuator.</p>

FAULT	CAUSES	CORRECTIVE ACTIONS
<p>Command Overrun Fault</p>	<p>A new command was received by the actuator while the previous command had not completed.</p> <p><i>This should not be a permanent fault and should clear after a while.</i></p>	<p>Reset your haptic system in the Haptic Output tab of D-BOX HaptiSync Center, under either the Settings or Status tab by clicking the Reset Unit button.</p> <p>Power off the haptic system, wait for a minute, then try again.</p> <p>In HaptiSync Center, check if there is any other faults and follow the recommended solution.</p> <p>If the error persists, contact your reseller support team or D-BOX Technical Support if your system was purchased directly from D-BOX.</p>
<p>Critical Actuator Fault</p>	<p>Something may be blocking the actuator. This is a hard fault.</p> <p><i>The faulty actuator is immediately deactivated to prevent damage, and all other actuators go to the lowest position.</i></p>	<p>Check if there is anything blocking the travel of the actuator.</p> <p>Power off the haptic system, support your platform to gain access to the actuator piston and slowly pull it out of its body until the entire piston is out, and then slowly push it back in.</p> <p>If the error persists, replace/arrange to repair the faulty actuator.</p>
<p>Encoder Fault</p>	<p>There is a problem with the motor encoder.</p>	<p>Power off the haptic system, wait for a minute, then try again.</p> <p>If the error persists, replace/arrange to repair the faulty actuator.</p>
<p>High Voltage Rail Overvoltage Fault</p>	<p>Too high a voltage detected.</p> <p>Voltage from the wall outlet is too high for the haptic system.</p>	<p>Verify that all actuators are set to your region's power voltage.</p> <p>Make sure you are not connected to a GFI breaker.</p>
<p>High Voltage Rail Undervoltage Fault</p>	<p>Too low voltage detected.</p> <p>Voltage from the wall outlet is too low for the haptic system.</p>	<p>Check the power coming out of the outlet and make sure it respects the specified operating conditions. When in doubt, connect the haptic system to another circuit.</p> <p>Visually inspect the entire length of the power cable for obvious signs of damage.</p>

FAULT	CAUSES	CORRECTIVE ACTIONS
<p>Logic Voltage Undervoltage Fault</p>	<p>Too low a voltage detected.</p> <p>Defective or disconnected power cable.</p> <p>Low-voltage rail is too low.</p>	<p>Make sure you are connected to a grounded electrical outlet.</p> <p>NOTE: <i>Do not use adapter plugs or remove the grounding prong from cables. If you must use an extension cable, use a 3-wire cable with properly grounded plugs.</i></p> <p>If you are using an extension cable, try again without it.</p> <p>If the error persists, replace/arrange to repair the faulty actuator.</p>
<p>Motor Temperature High Fault</p>	<p>The motor temperature detector has failed or disconnected.</p>	<p>Make sure that the maximum supported weight for the platform has not been exceeded.</p> <p>The weight (in D-BOX Newtons) must respect the limits identified in the Actuators section. Confirm the weight in the Haptic Output tab of D-BOX HaptiSync Center, under Diagnostics.</p>
<p>Motor Temperature Sensor Fault</p>	<p>The temperature is too low.</p> <p>If the temperature reads around 561°F, it may be a defective motor cable or temperature sensor.</p>	<p>Make sure that the weight is evenly distributed among the actuators of the platform (as centered as possible).</p> <p>Make sure the haptic system is operating in normal operating conditions (room temperature).</p> <p>If the error persists, replace/arrange to repair the faulty actuator.</p>
<p>Out of bounds Fault</p>	<p>The position of the actuator is over its limits (Should never occur in normal conditions).</p> <p>The haptic code may have sent the actuator out of bounds.</p>	<p>Verify that you are running a D-BOX-certified haptic code. Call D-BOX Technical Support for validation if necessary.</p> <p>Perform a test using by clicking Start Haptic System Test on the Haptic Output tab of D-BOX HaptiSync Center.</p>
<p>Overcurrent Fault</p>	<p>An actuator might have the wrong configuration (e.g. set to a 250-lb motor instead of a 400-lb).</p>	<p>Make sure you have the right configuration using D-BOX System Configurator.</p> <p>If the error persists, contact your reseller support team or D-BOX Technical Support if your system was purchased directly from D-BOX.</p>

FAULT	CAUSES	CORRECTIVE ACTIONS
<p>Overweight Fault</p>	<p>There is too much weight on the platform.</p> <p>The weight on the platform is unbalanced.</p>	<p>Make sure that the maximum supported weight for the platform has not been exceeded.</p> <p>The weight (in D-BOX Newtons) must respect the limits identified in the Actuators section. Confirm the weight in the Haptic Output tab of D-BOX HaptiSync Center, under Diagnostics.</p> <p>Make sure that the weight is evenly distributed among the actuators of the platform (as centered as possible).</p> <p>If the error persists, contact your reseller support team or D-BOX Technical Support if your system was purchased directly from D-BOX.</p>
<p>Power Bridge Temperature High</p>	<p>The actuator power bridge has overheated, or the sensor is defective.</p>	<p>Power off the haptic system, wait for a minute then try again.</p> <p>Let the system cool down for a while and see if the temperature cools within normal limits.</p> <p>If the error persists, contact your reseller support team or D-BOX Technical Support if your system was purchased directly from D-BOX.</p>
<p>Soft Actuator Fault</p>	<p>This fault is always accompanied by another fault, which is the primary reason (fault).</p>	<p>Consult the solution for the primary fault causing the Soft Actuator fault.</p>
<p>Temporary Actuator Fault</p>	<p>This fault is always accompanied by another fault, which is the primary reason (fault).</p>	<p>Consult the solution for the primary fault causing the Temporary Actuator Fault.</p>
<p>Travel Fault</p>	<p>The travel measure during the search-stop procedure is too large or too small.</p> <p>An external factor preventing the actuator from moving.</p> <p>A defective actuator.</p> <p>A communication issue with the encoder.</p>	<p>Check if there is anything blocking the travel of the actuator.</p> <p>Power off the haptic system, support the platform to gain access to the actuator piston and slowly pull it out of its body until the entire piston is out, and then slowly push it back in.</p> <p>If the error persists, replace/arrange to repair the faulty actuator.</p>

12.7 Troubleshooting Software Issues (D-BOX HaptiSync Center)

This section covers the procedure for fixing issues related to the software or haptic code.

STEP 1: Make sure you are using the latest version of [D-BOX HaptiSync Center](#).

STEP 2: Make sure that your HaptiSync Mode is set to **D-BOX Coded Gaming**.

STEP 3: In the Haptic Output tab, start a motion and communication test by clicking **Start Haptic System Test**.

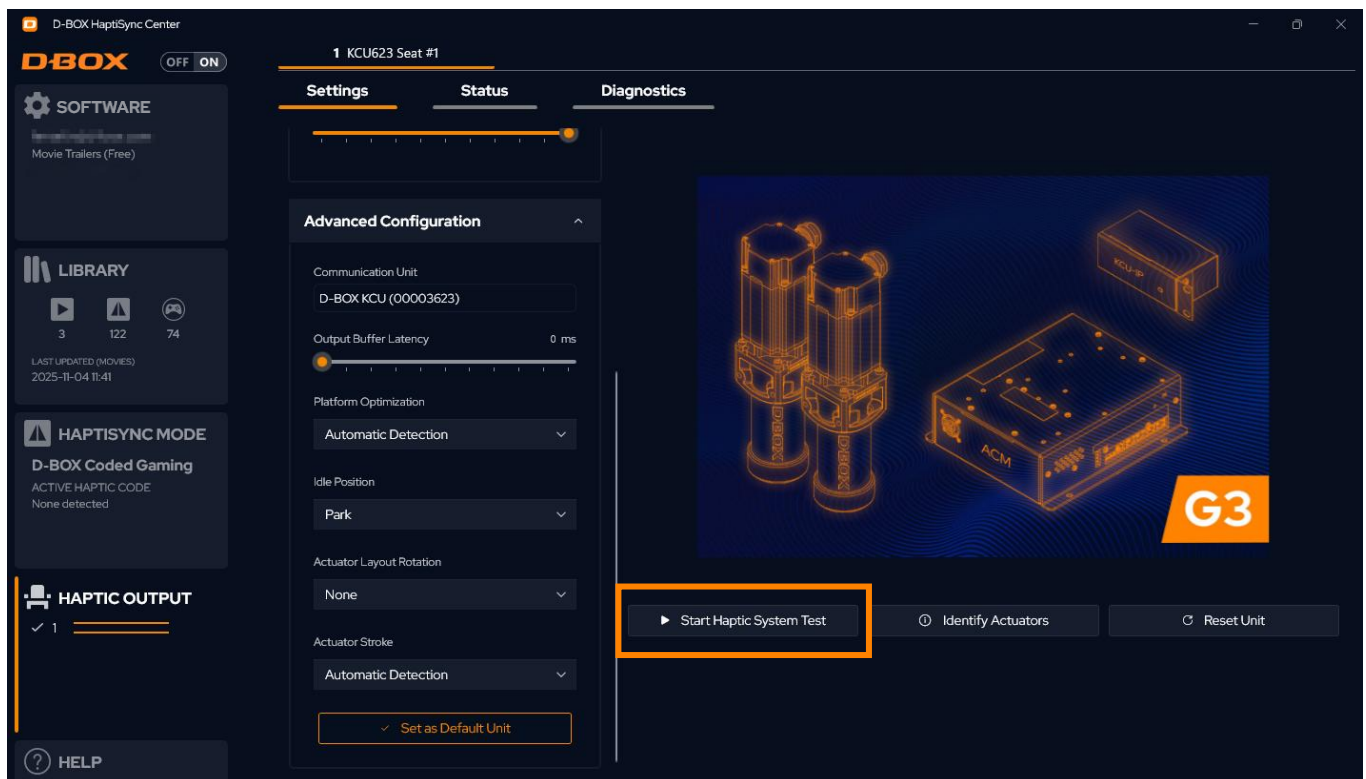

STEP 4: Make sure you have the latest version of the haptic code installed. If there is a newer version available, click **Update Haptic Code**.

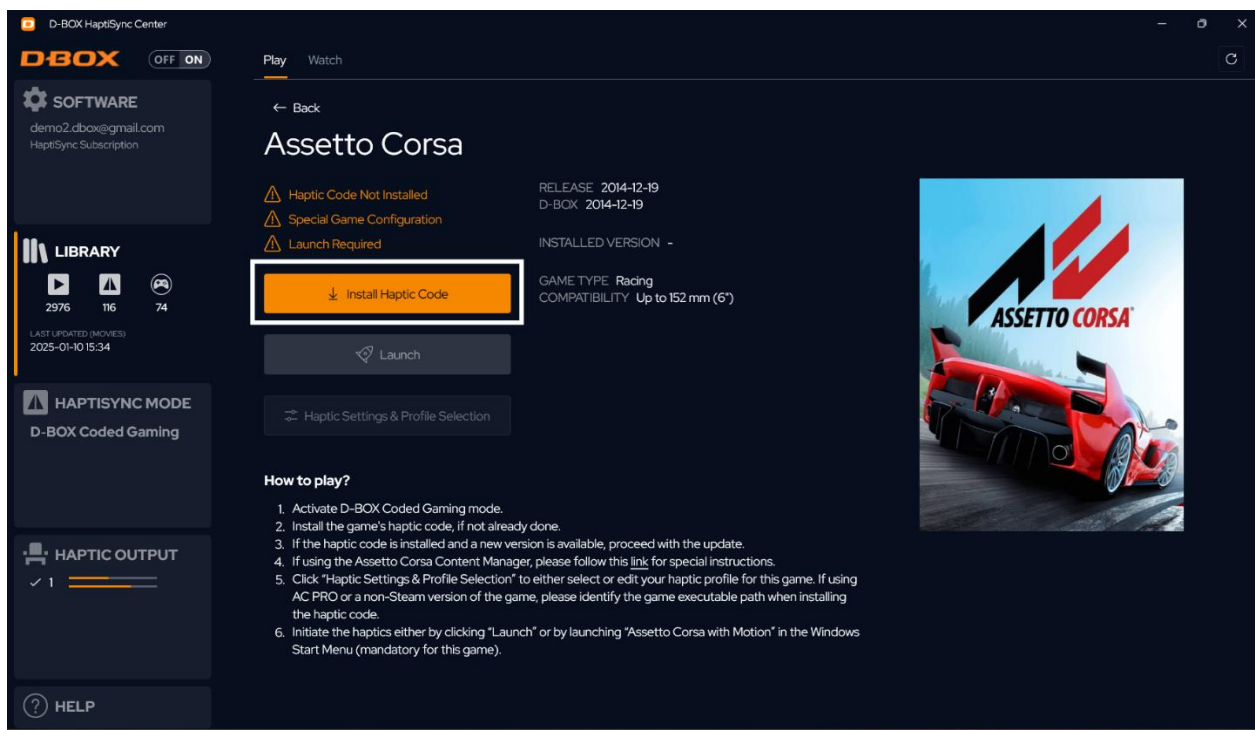

STEP 5: Make sure to launch the game from D-BOX HaptiSync Center. Select the game then click the **Launch** button at the bottom.

NOTE: Some games may need to be launched in a specific way. Follow the detailed instructions.

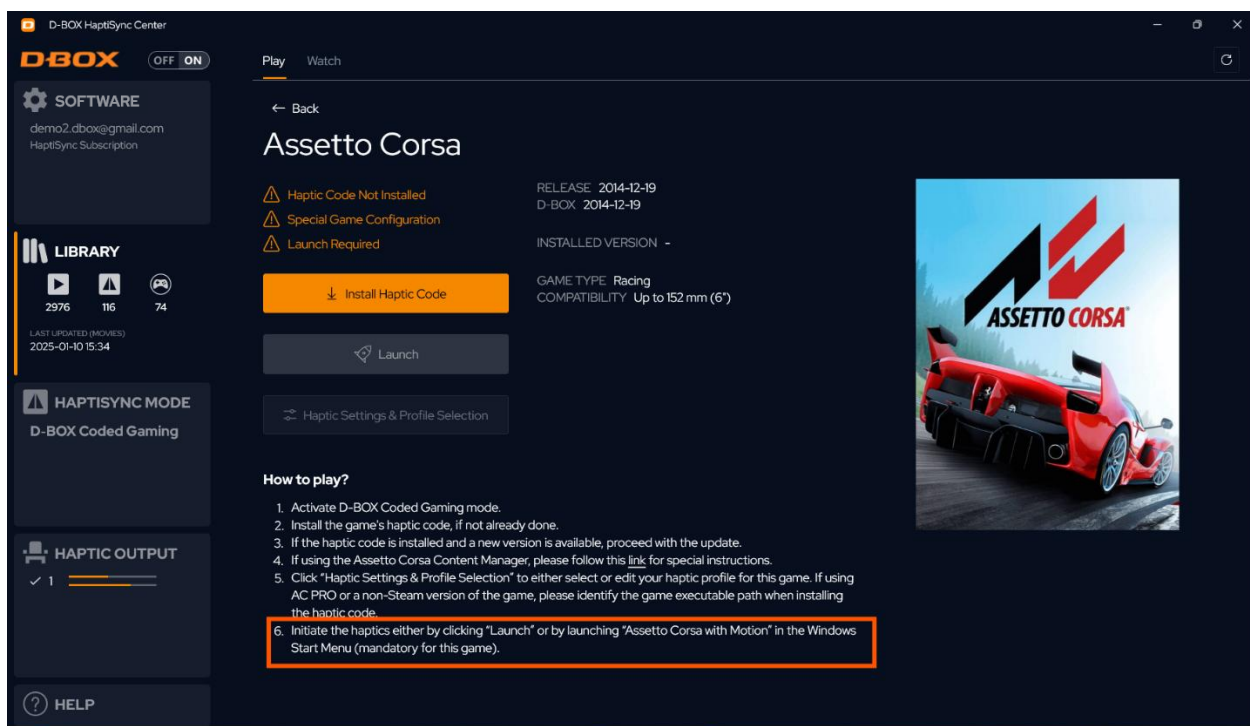

APPENDIX A - INFORMATION FOR COMMERCIAL USE

This information is intended for integrators who use G3 haptic systems in an integrated simulation platform. It is not applicable if the system is used for personal applications (e.g. Sim Racing, home entertainment, etc.).

Mechanical Integration

To complete your mechanical integration phase:

- **Consult all relevant documentation:** Installation guides contain important information about integrating and using our products. Respecting all specifications and guidelines helps to keep your product in good shape and optimize its service lifetime. Our guides are available via our [website](#); however, do not hesitate to contact our team if you cannot find the information you require.
- **Share your design with us for review and recommendations:** Once your CAD integration is completed, our team will confirm that the design respects our guidelines. All D-BOX 3D product files are available in .stp format upon request.
- **Complete a finite element analysis (FEA):** Once the design is final, the FEA highlights potential design flaws and ensures the service lifetime corresponds to your requirements.
- **Complete life cycle tests with proper load and waves:** Life cycle tests performed using D-BOX haptic codes are representative of typical usage.

Software Integration

To complete your software integration phase:

- **Set up your D-BOX Connect account:** [D-BOX Connect](#) is used for haptic code distribution and authorization service. The account is required to install and update haptic codes for D-BOX Coded Gaming and to access haptic codes for D-BOX Coded Video.
- From our [website](#):
 - Download and install the **D-BOX HaptiSync Center** software suite.
 - Download and install **D-BOX System Configurator**.
- **Integrate the [Monitoring and Diagnostics API](#).** This application provides live health and operational data for the haptic system. The default TCP communication port is 40001, but this value can be modified with the configuration file. The internal polling interval is 100 ms, so your application should poll at an equal or slower rate.

Haptic Code Integration

D-BOX haptic codes are readily compatible with many types of content (2D, 3D, linear, interactive). Details can be found in D-BOX HaptiSync Center.

Our team can create custom haptic codes for your specific needs (e.g. for linear content like clips, movies, etc.).

- **Send us your preliminary assets for evaluation:** Our team will evaluate the time required to create the haptic code. We will also provide recommendations for improving the global experience, if possible.
- **Send us your final assets with your directives:** Our team will go through the creation process and send you the necessary files, in the appropriate format.
- **Test the experience and send us your comments:** Let us know if you feel that the experience needs improvement.

Our team of haptic designers have experience in creating haptic codes for various types of content and will be helpful in creating a rich experience. Remember, there are no autonomous methods of creating haptic codes.

If you require a custom haptic code for interactive content, refer to the following instructions:

- **Integrate the D-BOX Live Motion SDK into your software:** Live Motion SDK allows you to submit live events that are processed by the matching haptic code and then turned into a corresponding immersive haptic signal. Our SDK is well documented and available upon request.
- **Send us logs and videos:** Even though it might be difficult for you to produce, our team requires the actual assets to start the haptic code creation process. A description of the required logs and video would be shared with you before the beginning of the process.
- **Test the experience and send us your comments for iteration** if you feel like the experience needs improvement: Our team will also send you recommendations to improve the overall experience and will support the iteration until both parties are satisfied with the results.

NOTE: *D-BOX haptic integrators have experience creating haptic codes for various content. Working with us will allow for an optimal experience. However, we offer different integration methods if you prefer more autonomy. Contact our Sales team for details.*

APPENDIX B - G3 HAPTIC SYSTEMS USING OLDER ACM VERSIONS (ACM G3 or ACM G2 with a KCU-1P)

There are two types of ACM G3: with Discharge, and with Discharge and Fan.

ACM G3	TRAVEL	MODEL	MAX NUMBER OF ACTUATORS PER ACM
ACM G3 w DISCHARGE MAIN, SECONDARY	1.5 in	250i	2
		400i	
		250HD	
		400HD	
	3 in	250i-3	2
		400i-3	
ACM G3 w DISCHARGE & FAN MAIN, SECONDARY	6 in	500HD	2

Compatibility

ACM G3 FLEX is compatible with ACM G3 or ACM G2, but the ACM G3 FLEX must be the MAIN ACM, or the last SECONDARY ACM in the haptic system.

ACM G3 and G3 FLEX are compatible with ACM G2—they are not compatible with ACM G1.

IMPORTANT:

- ACMs are programmed to work with a specific actuator model and at a specific place in the architecture (Main/Secondary). Thus, ACMs are not interchangeable but can be reconfigured using D-BOX System Configurator. Different families of products' components are not compatible with each other.

Connecting a G3 Haptic System with ACM G3

Depending on the ACM's position in the system, it is either programmed as:

- **MAIN:** The first ACM in a haptic system
- **SECONDARY:** All following ACMs

The last MAIN and SECONDARY ACMs in a chain must always be terminated using a shielded, 1-foot CAT5E or CAT6A cable, connecting the OUT to the END port of the ACMs.

Typical ACM Configurations for a Single Haptic System

1 ACM (1 or 2 actuators)

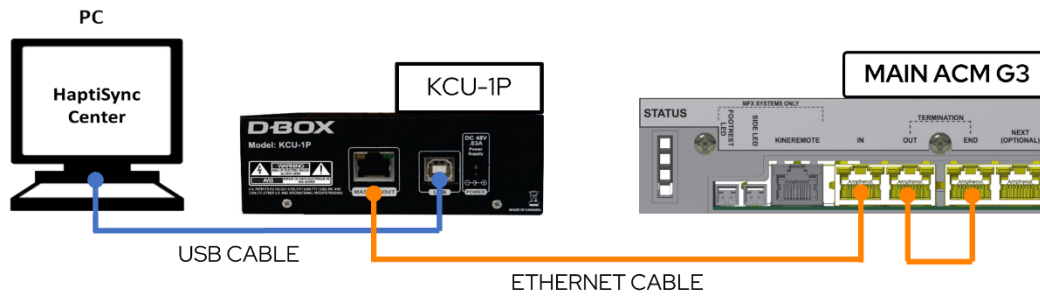

2 ACMs (3 or 4 actuators)

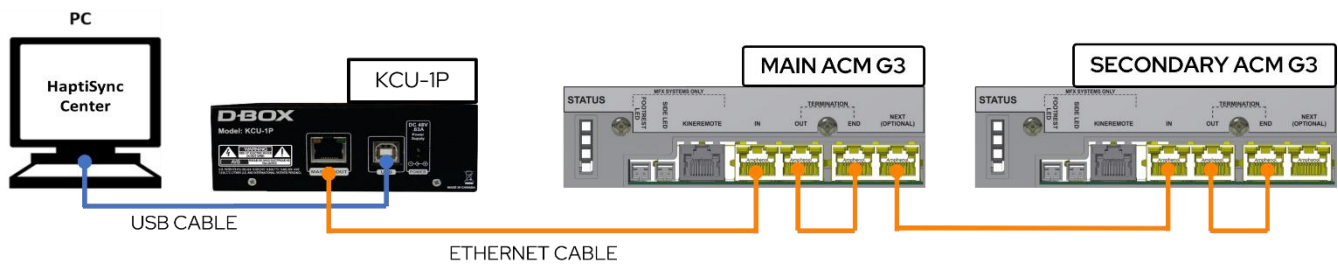

4 ACMs (7 or 8 actuators)

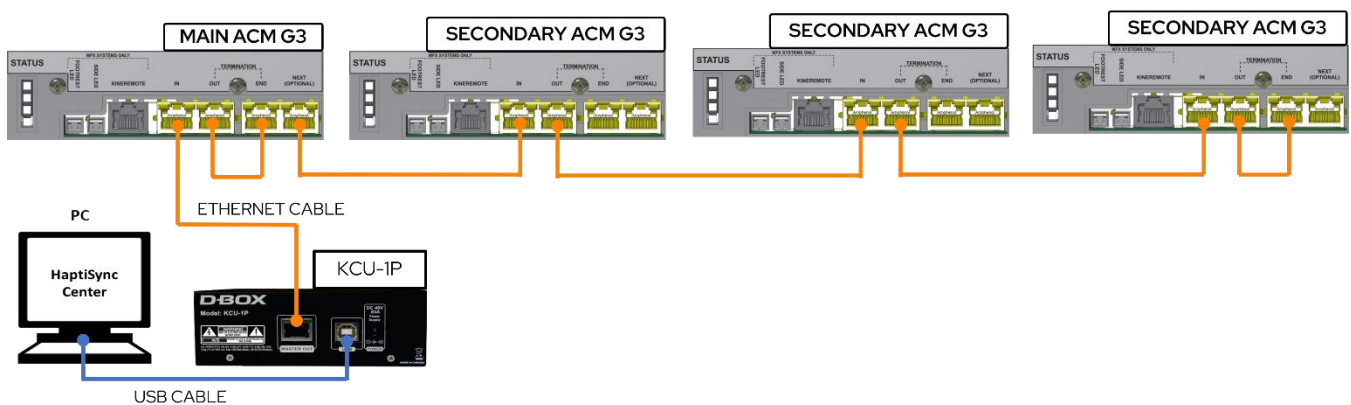

3 D-BOX Haptic Systems Using 2 ACMs G3 each (daisy-chained)

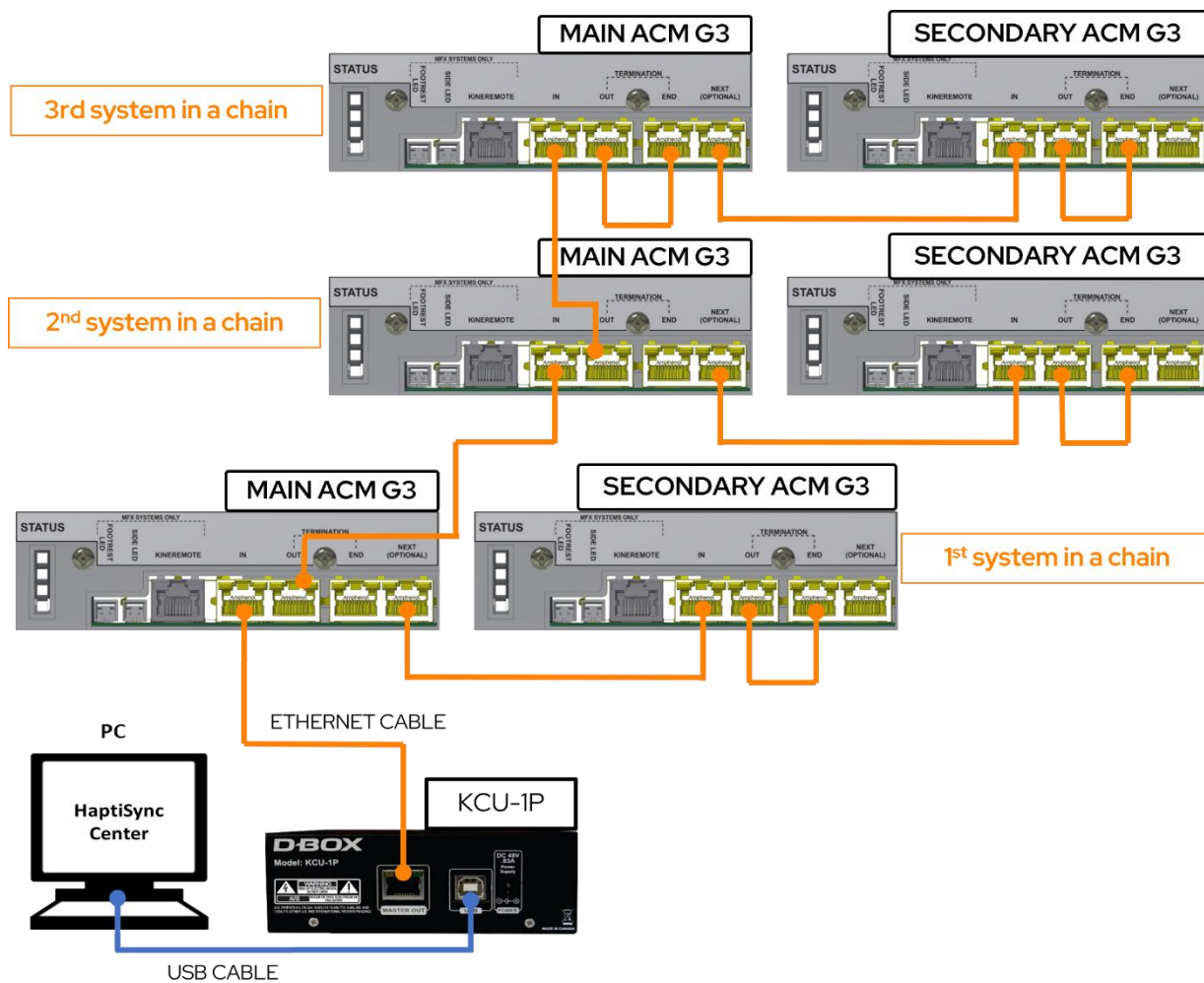

Setting up a G3 Haptic System with both ACM G3 and ACM G3 FLEX

ACM G3 is compatible with ACM G3 FLEX. The ACM G3 FLEX can be configured either as a MAIN or as the last SECONDARY ACM; therefore:

- If you have two ACMs in your system, you can replace either the MAIN or the SECONDARY ACM.
- If you have three ACMs in your system, you can replace either the MAIN or the third ACM (last SECONDARY). If you need to replace the second ACM, please contact our support team to reprogram/rearrange your ACMs to ensure the ACM G3 FLEX is correctly positioned.
- If you have four ACMs in your system, you can replace either the MAIN or the fourth ACM (last SECONDARY). If you need to replace the second or third ACM, please contact our support team to reprogram/rearrange your ACMs to ensure the ACM G3 FLEX is correctly positioned.

Examples of haptic systems with G3 and G3 FLEX ACMs

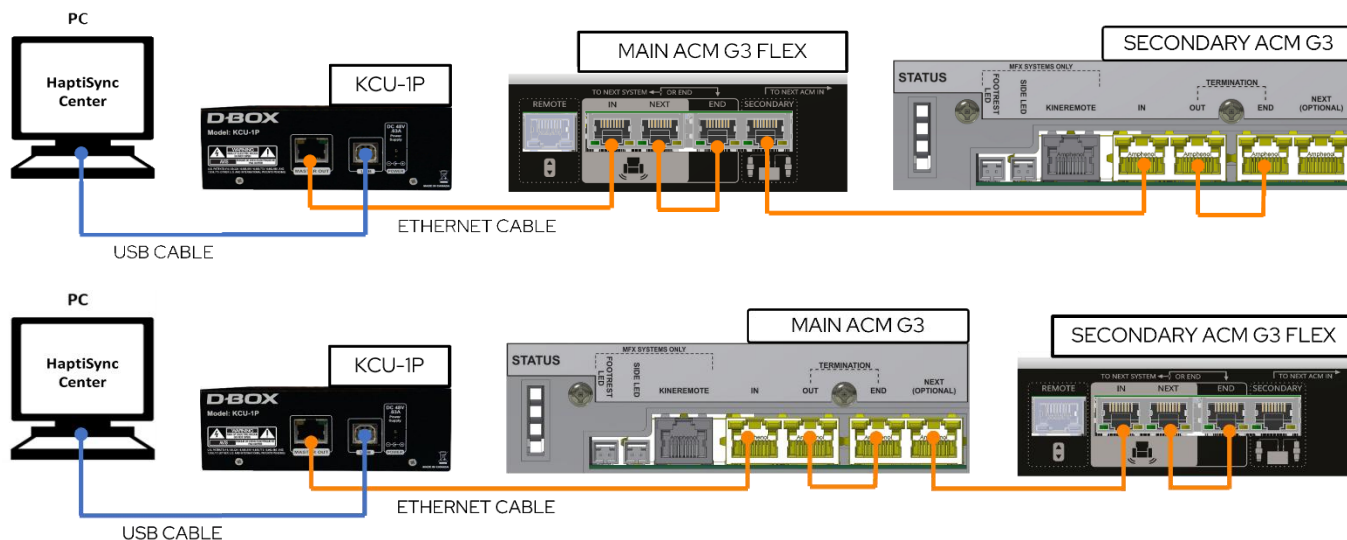

Setting up a G2 Haptic System with both ACM G2 and ACM G3 FLEX

ACM G2 is compatible with ACM G3 FLEX. The ACM G3 FLEX can be configured either as a MAIN or as the last SECONDARY ACM; therefore:

- If you have two ACMs in your system, you can replace either the MAIN or the SECONDARY ACM.
- If you have three ACMs in your system, you can replace either the MAIN or the third ACM (last SECONDARY). If you need to replace the second ACM, please contact our support team to reprogram/rearrange your ACMs to ensure the ACM G3 FLEX is correctly positioned.
- If you have four ACMs in your system, you can replace either the MAIN or the fourth ACM (last SECONDARY). If you need to replace the second or third ACM, contact our support team to reprogram/rearrange your ACMs to ensure the ACM G3 FLEX is correctly positioned.

Examples of haptic systems with ACM G2 and ACM G3 FLEX

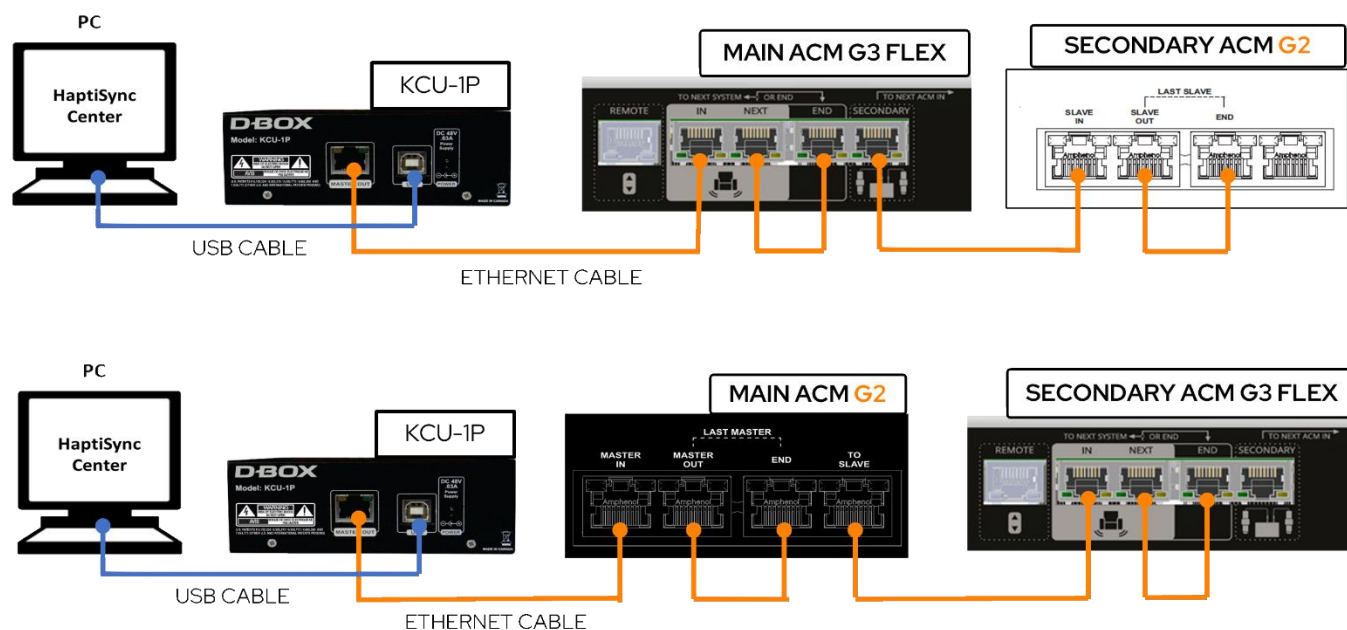

Setting up a G3 Haptic System with both ACM G3 and ACM G2

ACM G3 is compatible with ACM G2. The ACM G2 can be configured either as a MAIN or a SECONDARY ACM.

If you are connecting a SECONDARY ACM G2 to a G3 haptic system, please refer to the diagram below and note the following:

- You will be able to use D-BOX System Configurator to change the configuration; however, you will not be able to change the actuator type or reorder the ACMs.
- Make sure to mention that your architecture is composed of a mix of both families of products when contacting your reseller support team or D-BOX Technical Support.

Example of a haptic system with G2 and G3 ACMs

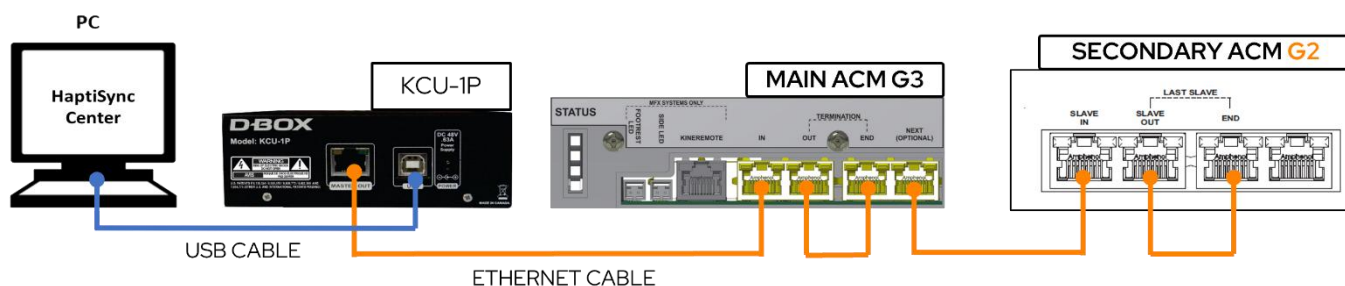

APPENDIX C - MIXING G5 AND G3 HAPTIC SYSTEMS (ACM G3 FLEX ONLY connected to a KCU-1X)

These configurations require connecting your PC to a KCU-1X Communication Unit—the KCU-1X to the main ACM G3 FLEX—the main ACM G3 FLEX to a Haptic Expander—Haptic Expander to the G5 actuators.

NOTE:

- Remember to update your firmware whenever making a change to your setup/configuration.
- A Haptic Expander (HX4) is required when mixing a G3 haptic system (ACM G3 FLEX only) using one or more actuators (maximum of four) and a G5 haptic system using two or more actuators (connected to the REMOTE port of the Main ACM).

Option1 (4 G5s Roll-Pitch-Heave/1 or 2 G3s Yaw, Sway, Surge, Yaw-Sway, Yaw-Surge, or Sway-Surge)

Configuration # 1095, 1096, 1097, 1098, 1099, or 1100

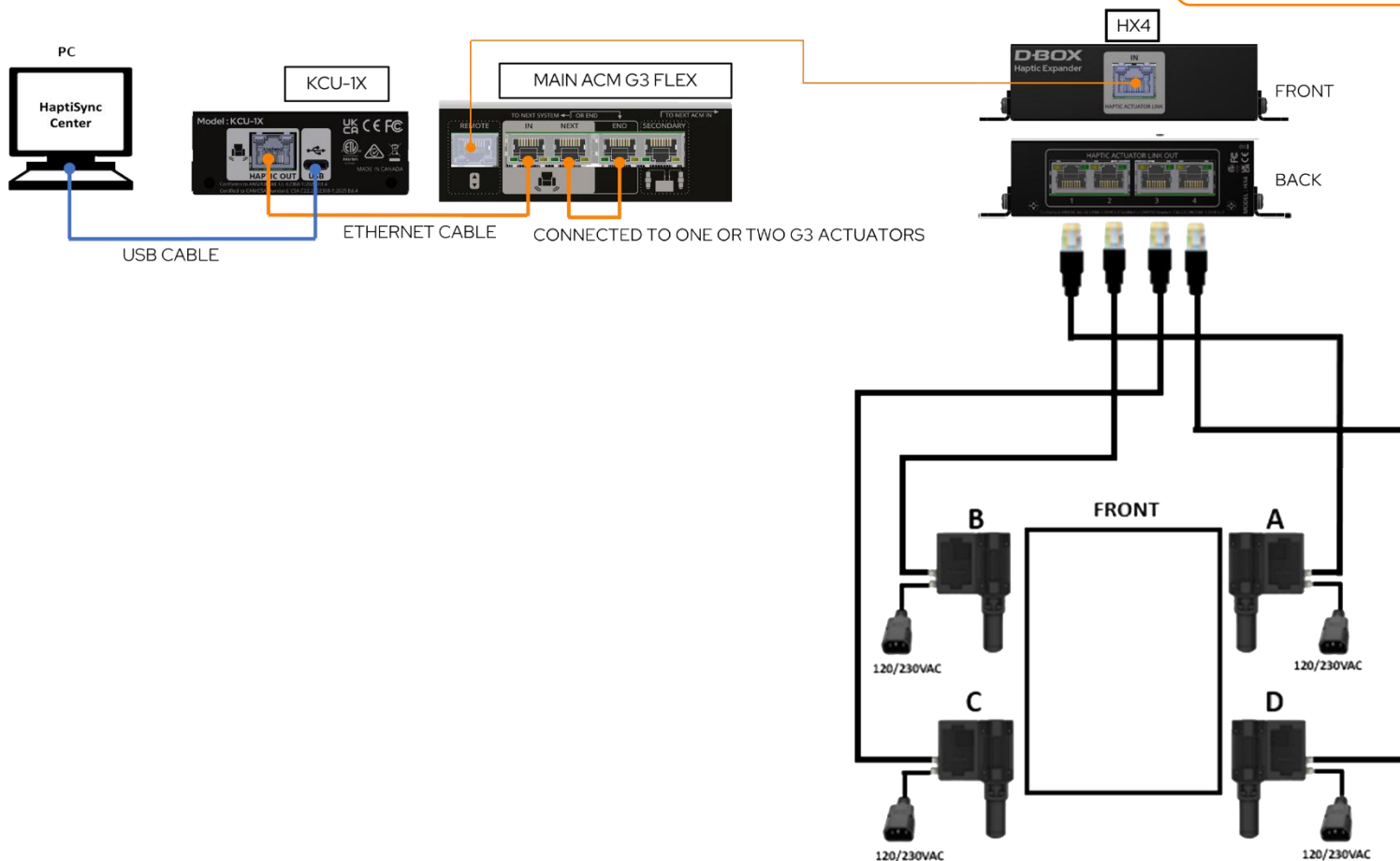

Option 2 (4 G5s Roll-Pitch-Heave / 3 G3s Yaw-Sway-Surge)

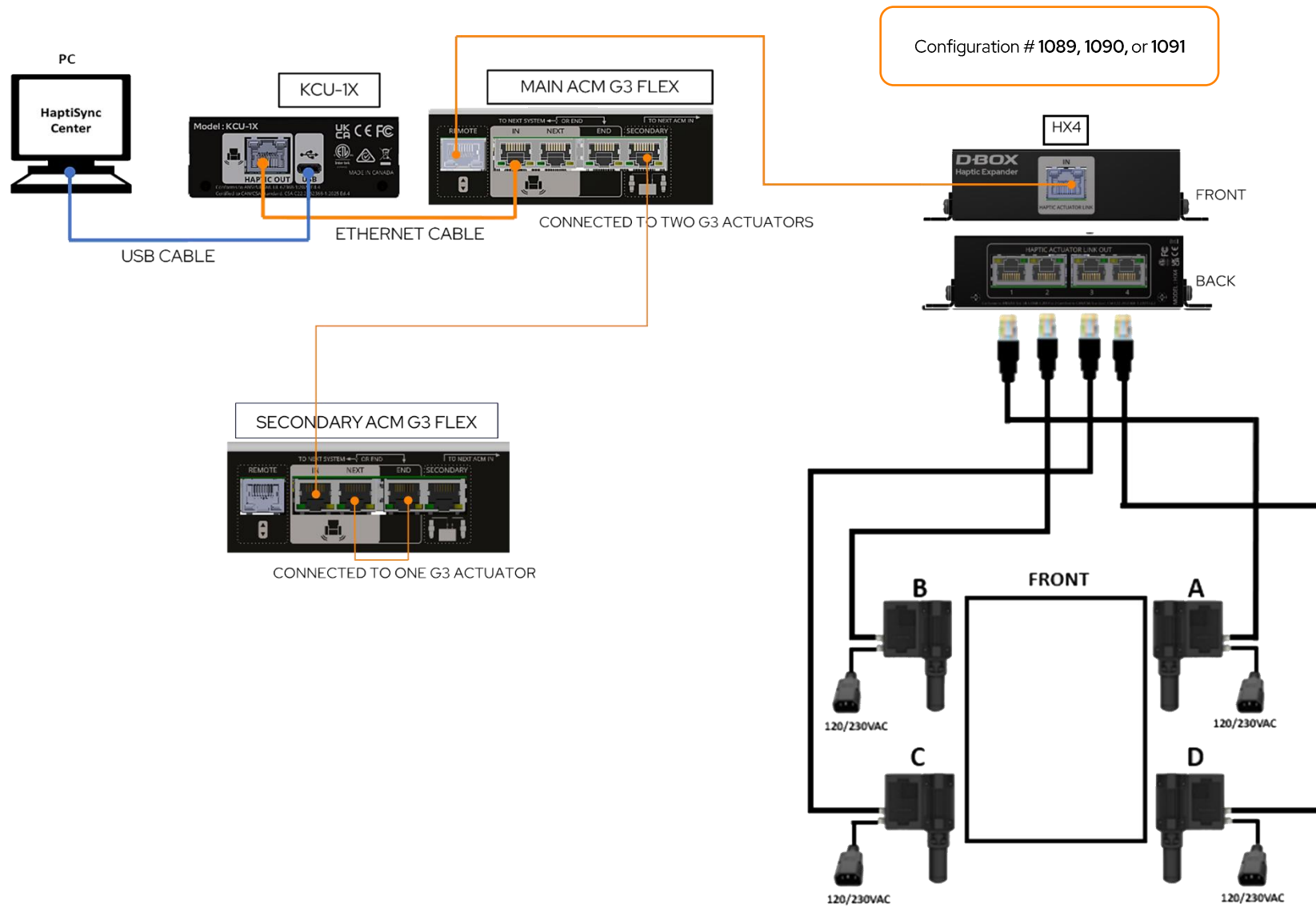

Option 3 (4 G3s Roll-Pitch-Heave/2 G5s Yaw-Sway, Yaw-Surge, or Sway-Surge)

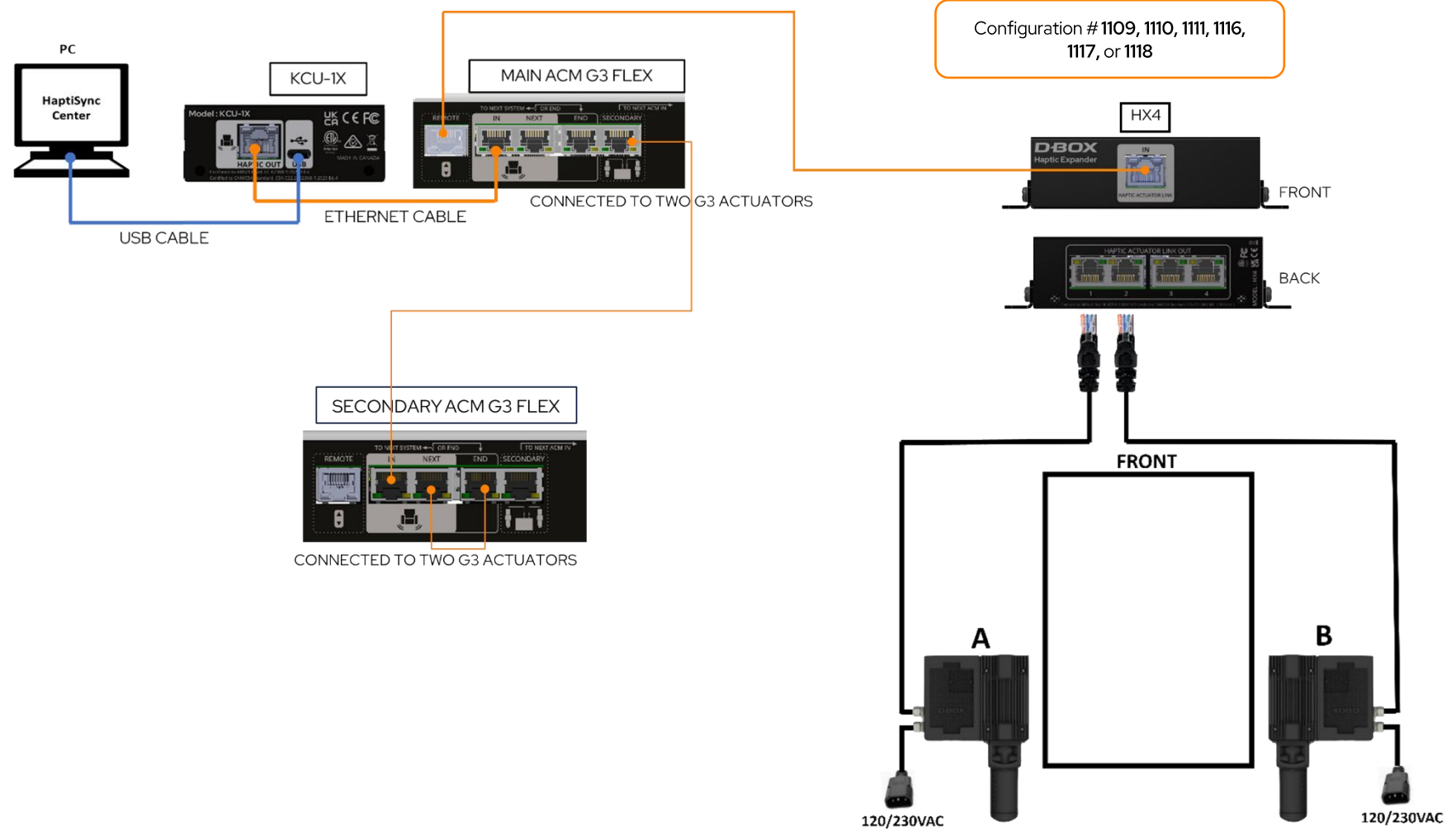

Common Configurations

NOTE: The following list does not represent every possible mixed configuration. See the System Configurator for more information.

Actuators	Number of ACM G3 FLEX	Configuration #	Description
4-G5, 1-G3	1	1098	G5 Roll-Pitch-Heave / G3 Yaw (M-Y1, S-FR0, S-FLO, S-BLO, S-BR0)
4-G5, 1-G3	1	1099	G5 Roll-Pitch-Heave / G3 Sway (M-Sw1, S-FR0, S-FLO, S-BLO, S-BR0)
4-G5, 1-G3	1	1100	G5 Roll-Pitch-Heave / G3 Surge (M-Su1, S-FR0, S-FLO, S-BLO, S-BR0)
4-G5, 2-G3	1	1095	G5 Roll-Pitch-Heave / G3 Yaw-Sway (M-Y0-Sw1, S-FR0, S-FLO, S-BLO, S-BR0)
4-G5, 2-G3	1	1096	G5 Roll-Pitch-Heave / G3 Yaw-Surge (M-Y0-Su1, S-FR0, S-FLO, S-BLO, S-BR0)
4-G5, 2-G3	1	1097	G5 Roll-Pitch-Heave / G3 Sway-Surge (M-Sw0-Su1, S-FR0, S-FLO, S-BLO, S-BR0)
4-G5, 3-G3	2	1089, 1090 or 1091	G5 Roll-Pitch-Heave / G3 Yaw-Sway-Surge 1089 (M-Y0-Sw1, S-Su1, S-FR0, S-FLO, S-BLO, S-BR0) 1090 (M-Y0-Su1, S-Sw1, S-FR0, S-FLO, S-BLO, S-BR0) 1091 (M-Y1, S-Sw0-Su1, S-FR0, S-FLO, S-BLO, S-BR0)
3-G5, 4-G3	2	1108	G3 Roll-Pitch-Heave / G5 Yaw-Sway-Surge (M-FR0-FL1, S-BLO-BR1, S-Y0, S-Sw0, S-Su0)
3-G5, 4-G3	2	1115	G3 Roll-Pitch-Heave / G5 Yaw-Sway-Surge (M-FLO-BL1, S-BR0-FR1, S-Y0, S-Sw0, S-Su0)

Actuators	Number of ACM G3 FLEX	Configuration #	Description
2-G5, 4-G3	2	1109	G3 Roll-Pitch-Heave / G5 Yaw-Sway (M-FRO-FL1, S-BLO-BR1, S-Y0, S-Sw0)
2-G5, 4-G3	2	1116	G3 Roll-Pitch-Heave / G5 Yaw-Sway (M-FLO-BL1, S-BRO-FR1, S-Y0, S-Sw0)
2-G5, 4-G3	2	1110	G3 Roll-Pitch-Heave / G5 Yaw-Surge (M-FRO-FL1, S-BLO-BR1, S-Y0, S-Su0)
2-G5, 4-G3	2	1117	G3 Roll-Pitch-Heave / G5 Yaw-Surge (M-FLO-BL1, S-BRO-FR1, S-Y0, S-Su0)
2-G5, 4-G3	2	1111	G3 Roll-Pitch-Heave / G5 Sway-Surge (M-FRO-FL1, S-BLO-BR1, S-Sw0, S-Su0)
2-G5, 4-G3	2	1118	G3 Roll-Pitch-Heave / G5 Sway-Surge (M-FLO-BL1, S-BRO-FR1, S-Sw0, S-Su0)
1-G5, 4-G3	2	1112	G3 Roll-Pitch-Heave / G5 Yaw (M-FRO-FL1, S-BLO-BR1, S-Y0)
1-G5, 4-G3	2	1119	G3 Roll-Pitch-Heave / G5 Yaw (M-FLO-BL1, S-BRO-FR1, S-Y0)
1-G5, 4-G3	2	1113	G3 Roll-Pitch-Heave / G5 Sway (M-FRO-FL1, S-BLO-BR1, S-Sw0)
1-G5, 4-G3	2	1120	G3 Roll-Pitch-Heave / G5 Sway (M-FLO-BL1, S-BRO-FR1, S-Sw0)
1-G5, 4-G3	2	1114	G3 Roll-Pitch-Heave / G5 Surge (M-FRO-FL1, S-BLO-BR1, S-Su0)

Actuators	Number of ACM G3 FLEX	Configuration #	Description
1-G5, 4-G3	2	1121	G3 Roll-Pitch-Heave / G5 Surge (M-FLO-BL1, S-BR0-FR1, S-Su0)
4-G5, 2-G3	2	1092	G5 Roll-Pitch-Heave / G3 Yaw-Sway (M-Y1, S-Sw1, S-FR0, S-FLO, S-BLO, S-BR0)
4-G5, 2-G3	2	1093	G5 Roll-Pitch-Heave / G3 Yaw-Surge (M-Y1, S-Su1, S-FR0, S-FLO, S-BLO, S-BR0)
4-G5, 2-G3	2	1094	G5 Roll-Pitch-Heave / G3 Sway-Surge (M-Sw1, S-Su1, S-FR0, S-FLO, S-BLO, S-BR0)
4-G5, 3-G3	3	1088	G5 Roll-Pitch-Heave / G3 Yaw-Sway-Surge (M-Y1, S-Sw1, S-Su1, S-FR0, S-FLO, S-BLO, S-BR0)
3-G5, 4-G3	4	1101	G3 Roll-Pitch-Heave / G5 Yaw-Sway-Surge (M-FR1, S-FL1, S-BL1, S-BR1, S-Y0, S-Sw0, S-Su0)
2-G5, 4-G3	4	1102	G3 Roll-Pitch-Heave / G5 Yaw-Sway (M-FR1, S-FL1, S-BL1, S-BR1, S-Y0, S-Sw0)
2-G5, 4-G3	4	1103	G3 Roll-Pitch-Heave / G5 Yaw-Surge (M-FR1, S-FL1, S-BL1, S-BR1, S-Y0, S-Su0)
2-G5, 4-G3	4	1104	G3 Roll-Pitch-Heave / G5 Sway-Surge (M-FR1, S-FL1, S-BL1, S-BR1, S-Sw0, S-Su0)
1-G5, 4-G3	4	1105	G3 Roll-Pitch-Heave / G5 Yaw (M-FR1, S-FL1, S-BL1, S-BR1, S-Y0)
1-G5, 4-G3	4	1106	G3 Roll-Pitch-Heave / G5 Sway (M-FR1, S-FL1, S-BL1, S-BR1, S-Sw0)

Actuators	Number of ACM G3 FLEX	Configuration #	Description
1-G5, 4-G3	4	1107	G3 Roll-Pitch-Heave / G5 Surge (M-FR1, S-FL1, S-BL1, S-BR1, S-Su0)